

ELECTRONIC HYGROSTAT

EFL 012



- > Large setting range
- > Compact design
- > Small hysteresis

- > Optical function display
- > Signal application

The electronic hygrometer is used for controlling heating and cooling equipment, filter fans or signal devices through the Relay SM 010 or a similar device. The hygrometer registers the surrounding relative humidity and can switch a signal current via an internal relay with a potential free change-over contact. The LED integrated in the adjustment knob shows the closed status of the contact 1-2. When relative humidity drops contact 1-2 opens and the LED turns off. In currentless state (no supply voltage) contact 1-2 opens.



TECHNICAL DATA

Switching difference	5 %RH (± 3 %RH tolerance) at +77 °F (+25 °C) and 50 %RH
Reaction time	approx. 5 sec.
Contact type	SPDT / change-over contact (relay)
Service life	>100,000 cycles (at 10 mW)
Max. switching capacity (relay output)	0.5 A at DC 48 V
Min. switching load	DC 10 mW (at 0.1V, 100 mA or 1 mA, 10 V)
Optical indicator	LED
Connection	5-pole terminal, clamping torque 0.5 Nm max.: solid/stranded ¹ wire - AWG 14 max. (2.5 mm ²)
Housing	plastic, UL 94V-0, light grey
Mounting	clip for 35 mm DIN rail, EN 60715
Mounting position	vertical
Operating / Storage temperature	+32 to +140 °F (0 to +60 °C) / -4 to +158 °F (-20 to +70 °C)
Operating / Storage humidity	max. 95 %RH (non-condensing)
Dimensions	2.54 x 1.65 x 1.5" (64.5 x 42 x 38 mm)
Weight	approx. 2.5 oz. (70 g)
Protection type	IP20

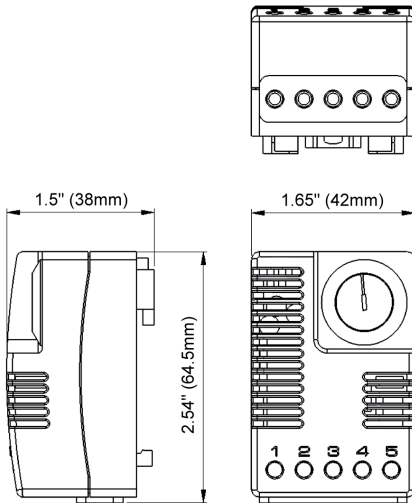

¹ When connecting with stranded wires, wire end ferrules must be used.

Connection diagram

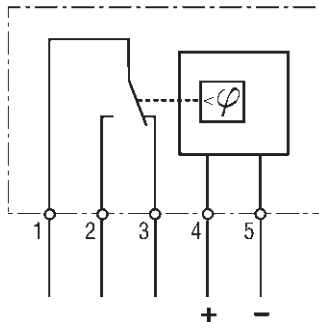

Wiring example

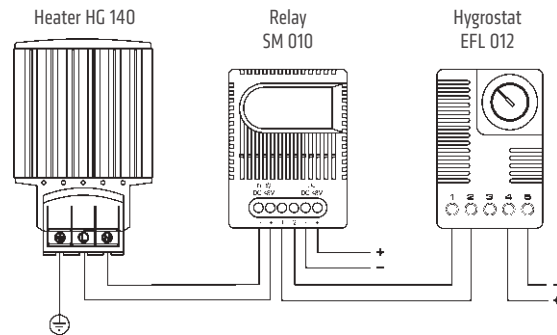

Part No.	Operating voltage	Setting range	Approvals
01245.2-00	DC 12-48 V (min. DC 10 V, max. DC 60 V)	40 to 90 %RH	UL File no. E164102, VDE submitted