

HAZARDOUS AREA HEATER

CREx 020 | 50 W to 200 W (T4)



- > For use in hazardous areas
- > Large convection surface
- > DIN rail and screw mounting
- > Ready-to-use with strain relief
- > Maintenance free
- > Temperature class T4

Compact convection heater of temperature class T4 (275 °F / 135 °C max.) for use in hazardous areas for prevention of formation of condensation, temperature fluctuations, and for protection against frost in control and switch cabinets, as well as in measuring equipment.



Photo Part No. 02042.0-00

H (Height)
W (Width)
D (Depth)

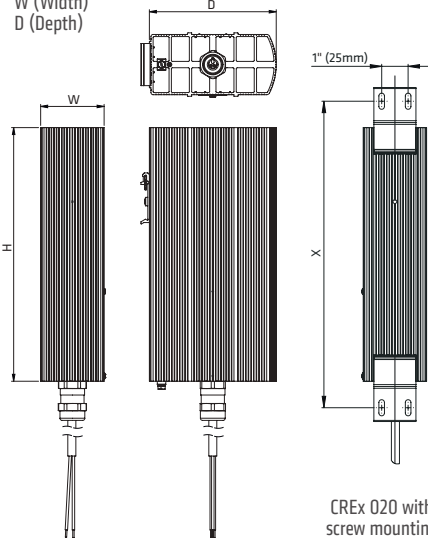

TECHNICAL DATA

Temperature class	T4
Ex Protection type	Ex II 2 GD
Gases	Ex db IIC T4 Gb
Dusts	Ex tb IIIC T135 °C Db IP66
Ambient temperature	-76 to +122 °F (-60 to +50 °C)
Surface temperature	max. +275 °F (+135 °C)
Heating element	high performance cartridge
Heating body	aluminum profile, silver anodized
Connection	silicone cable (halogen-free) 3 x AWG 18 (0.75 mm ²), length 3 ft (1 m)
Connection PE	AWG 18 to 14 (0.75 to 2.5 mm ²)
Mounting	clip for 35 mm DIN rail, EN 60715 for heating body sizes 3.2 x 1.9" and 4.7 x 2.4"; screw mounting with 2 mounting brackets for all heating body sizes, optional sideways mounting
Mounting position	vertical airflow (connection at bottom)
Storage temperature	-76 to +185 °F (-60 to +85 °C)
Operating / Storage humidity	max. 90 % RH (non-condensing)
Protection type / Protection class	IP66 / I (grounded)
Approvals	EPS 16 ATEX 1 109 X IECEx EPS 16.0048X EAC

DIN clip mount	Screw mounting brackets		Operating voltage	Heating capacity	Rec. pre-fuse T (time-delay)	Dimensions (D x W x H)	Weight approx.
Part No.	Part No.	Hole spacing X					
02041.0-00	02041.0-10	5.9" (150 mm)	AC 230 V	50 W	0.5 A	3.2 x 1.9 x 4.3" (80 x 48 x 110 mm)	1.5 lbs (0.7 kg)
02041.9-00	02041.9-10	5.9" (150 mm)	AC 120 V	50 W	1.0 A	3.2 x 1.9 x 4.3" (80 x 48 x 110 mm)	1.5 lbs (0.7 kg)
02042.0-00	02042.0-10	8.9" (225 mm)	AC 230 V	100 W	1.0 A	4.7 x 2.4 x 7.1" (120 x 60 x 180 mm)	3.1 lbs (1.4 kg)
02042.9-00	02042.9-10	8.9" (225 mm)	AC 120 V	100 W	2.0 A	4.7 x 2.4 x 7.1" (120 x 60 x 180 mm)	3.1 lbs (1.4 kg)
-	02043.0-10	10.8" (275 mm)	AC 230 V	150 W	1.5 A	6.3 x 3.2 x 8.6" (160 x 80 x 220 mm)	5.1 lbs (2.3 kg)
-	02043.9-10	10.8" (275 mm)	AC 120 V	150 W	3.0 A	6.3 x 3.2 x 8.6" (160 x 80 x 220 mm)	5.1 lbs (2.3 kg)
-	02044.0-10	13.8" (350 mm)	AC 230 V	200 W	2.0 A	6.3 x 3.2 x 11.8" (160 x 80 x 300 mm)	6.2 lbs (2.8 kg)
-	02044.9-10	13.8" (350 mm)	AC 120 V	200 W	4.0 A	6.3 x 3.2 x 11.8" (160 x 80 x 300 mm)	6.2 lbs (2.8 kg)