

MECHANICAL HYGROSTAT

Catalog No.	Used With	Height (A)	Width (B)	Depth (C)	Product Code
SCE-HYGRQ	Heater, Fan, Light	3.00	2.00	2.00	P1

Designed to regulate relative air humidity in enclosures. Mechanical hygrometers can operate with heaters, fans, or warning lights. Adjustable set point range of 40% to 90% humidity, maximum switch capacity 250V AC.

IS 24 - Industry Standards
UL Listed



BREATHER VENT

Catalog No.	Height (A)	Width (B)	Depth (C)	Product Code
SCE-BVK	2.75	2.00	1.50	P1

Designed for indoor or outdoor applications to handle the large negative pressure differential caused in a tightly sealed enclosure in extreme weather conditions or wash down applications that draw water into the enclosure. Adding a Breather Vent will equalize this pressure differential. Installed on the side of your enclosure as a breather or installed on the bottom as a drain and vent.

Made of corrosion and UV resistant Polycarbonate material.

UL Listed 1, 2, 3, 3R, 3RX, 3S, 4, 4X & 12

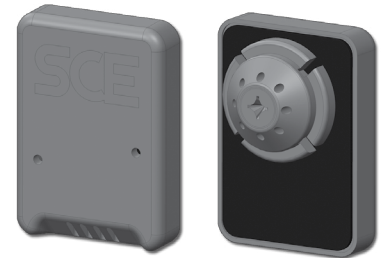

BLOWER PACKAGE

Catalog No.	Height (A)	Width (B)	Depth (C)	CFM	Voltage	Product Code
SCE-BP115	5.75	18.88	6.95	190/230	115	P1
SCE-BP230	5.75	18.88	6.95	190/290	230	

Designed for use in enclosures that require cooling but have limited space. Consists of a washable aluminum air filter, steel air plenum, removable stainless steel grille. Grille has captivated thumb nuts for easy access to the filter from the outside. Fan is 115 or 230 volt AC 50/60 Hertz (Hz). The 125 degree angled design provides greater air movement within the enclosure. Air plenum is ANSI 61 gray powder coated. UL listed motor.

IS 24 - Industry Standards
UL Listed

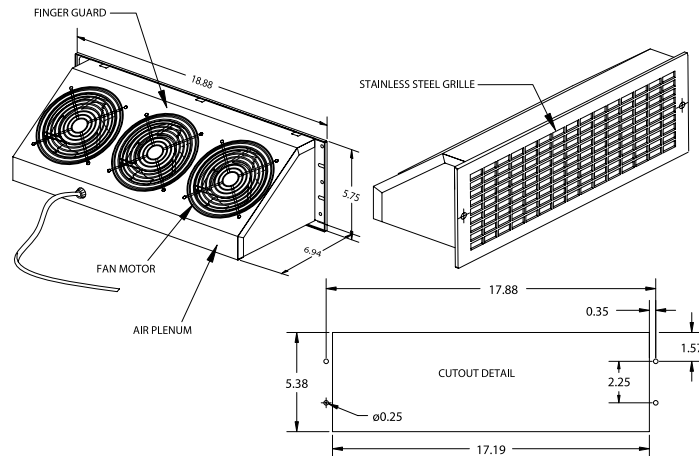

BLOWER PACKAGE (FILTER AND GRILLE)

Catalog No.	Height (A)	Width (B)	Depth (C)	Product Code
SCE-FGABP	5.75	18.88	0.22	P1

Designed for use with SCE Fan Packages and Filter and Grille Package. Aluminum washable filters provide good air filtration.

REMOTE TEMPERATURE DISPLAY

Catalog No.	Height (A)	Width (B)	Depth (C)	Product Code
SCE-RMTD	1.52	3.17	3.31	P1

