

SAGINAW CONTROL & ENGINEERING

SCE-48X2D7818

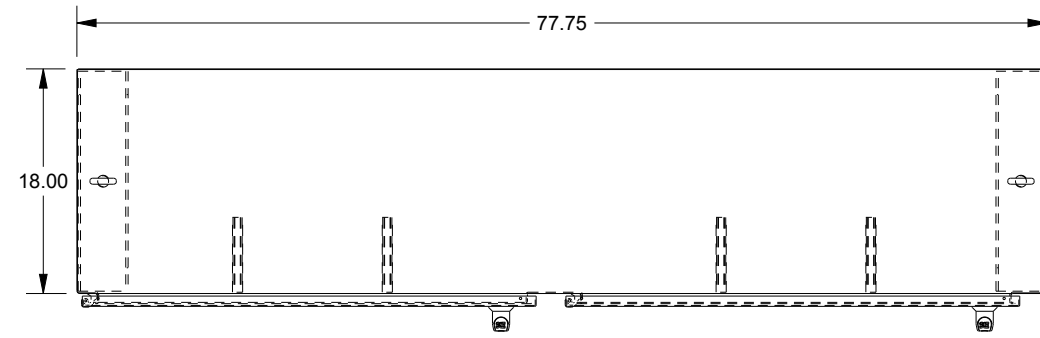

TOP VIEW

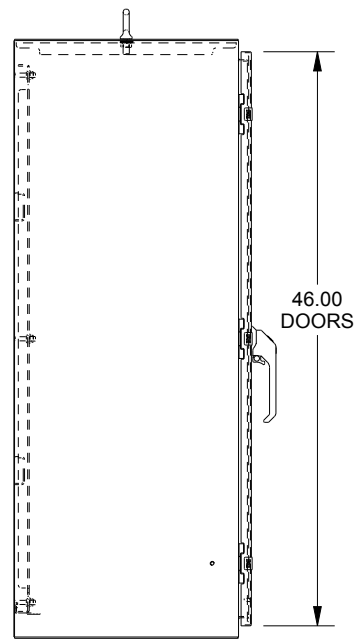

LEFT SIDE VIEW

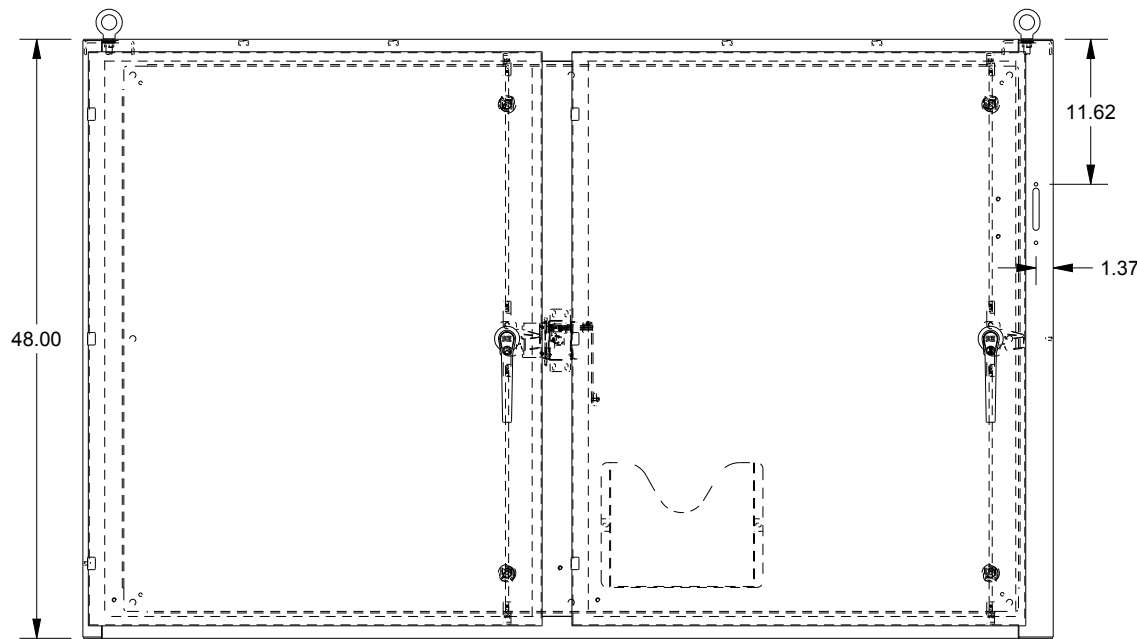

FRONT VIEW

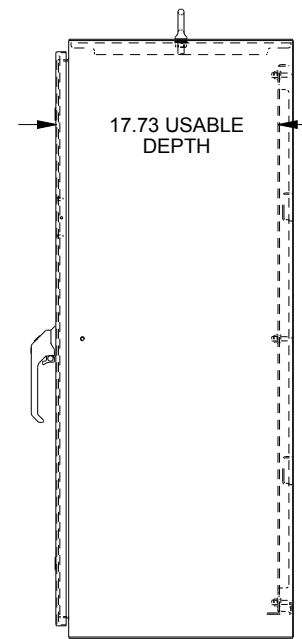

RIGHT SIDE VIEW

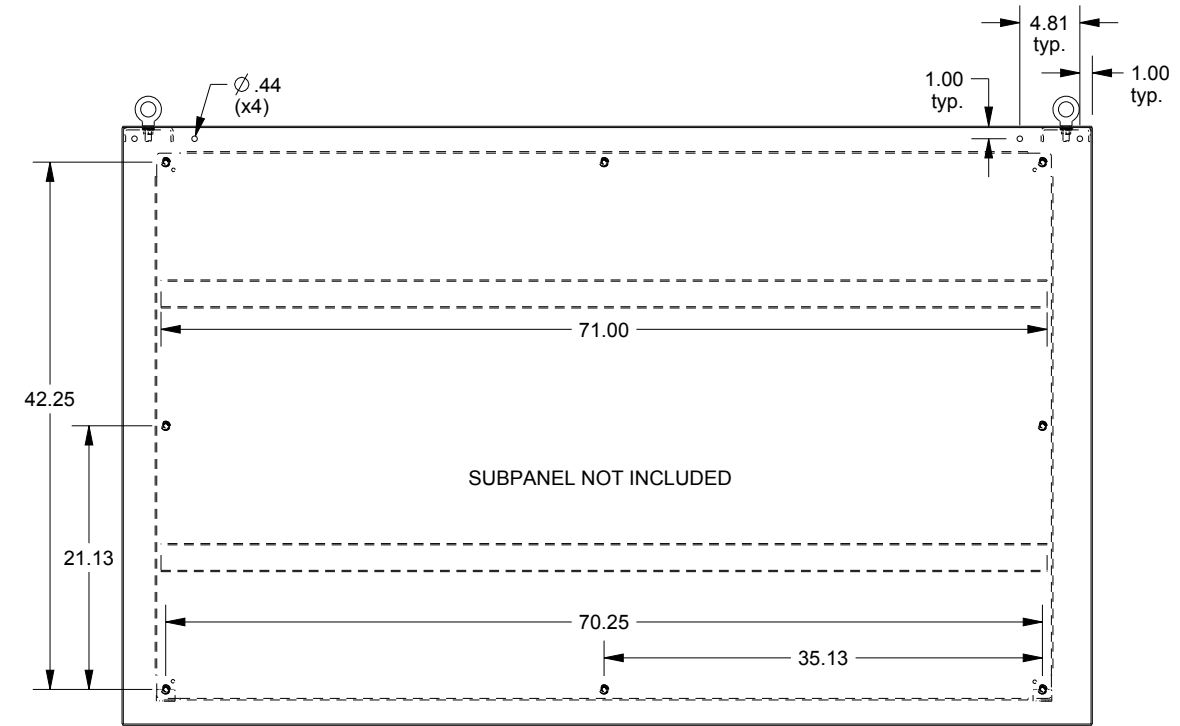

EXTERNAL REAR VIEW

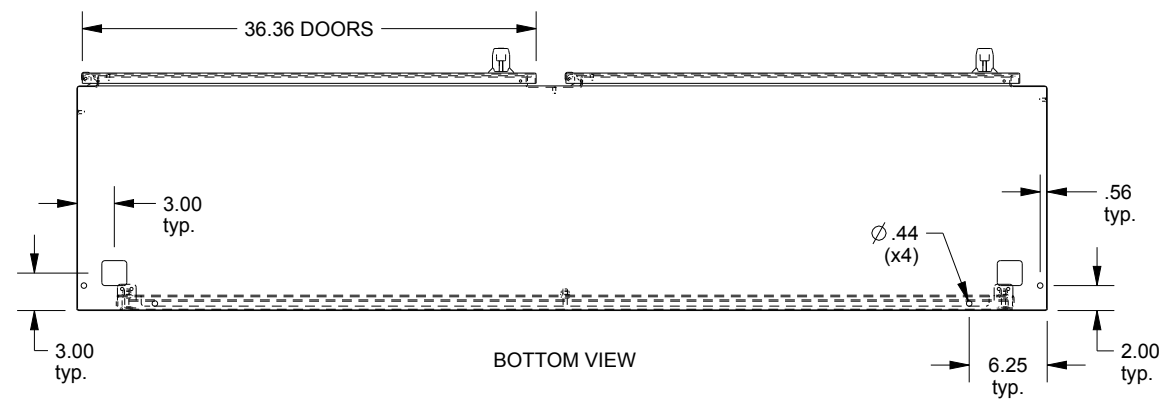

BOTTOM VIEW

CUTOUT PROVISIONS IN THE BOTTOM AND IN THE REAR WALL FOR SECURING OPTIONAL HEAVY DUTY WALL MOUNTING BRACKET KIT SCE-HDWMK

WASH SYSTEM 2" SQUARE DRAIN HOLES IN THE BOTTOM WITH UL APPROVED HOLE SEALS PROVIDED