

BILL OF MATERIAL

ITEM	QTY	PART DESCRIPTION	PART I.D.
1	1	Subpanel	NA

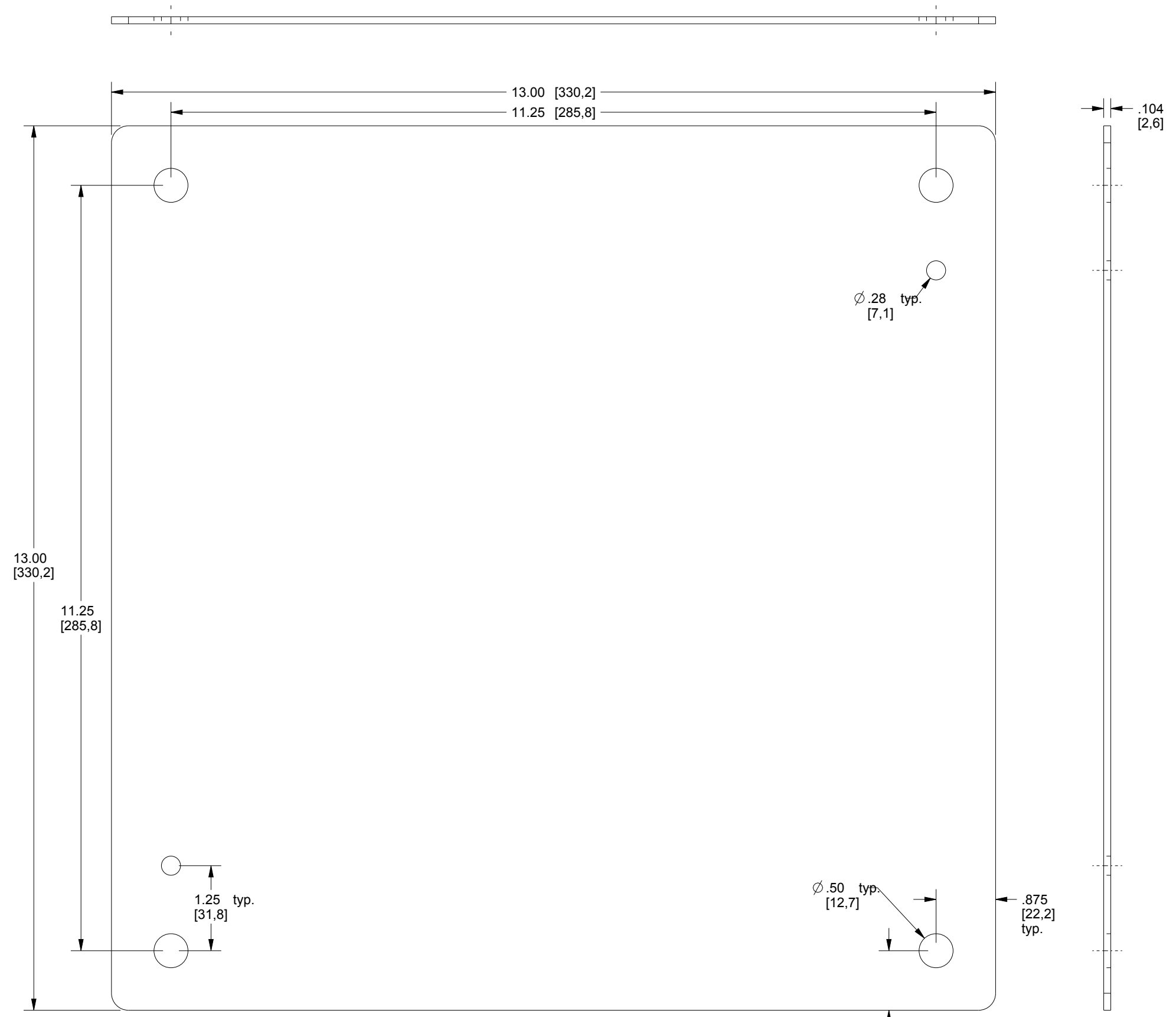

SUBPANEL FRONT VIEW

The material contained herein is the exclusive property of Saginaw Control & Engineering and must be returned to Saginaw Control & Engineering upon request. The information and material contained herein may not be copied, reproduced, used or transmitted in whole or in part in any way without the prior written consent of Saginaw Control & Engineering.

PART NUMBER: SCE-16P16SS	REV: --
12GA. #4 BRUSHED TYPE 304 STAINLESS STEEL MATERIAL	
SHEET: 1 OF 1	