

CM

Infrared Sensor



Operating Instructions



Rev. B1 Feb 2017
51101



The device complies with the requirements of the European Directives.

EC – Directive 2004/108/EC (EMC)

Contacts

Fluke Process Instruments

Fluke Process Instruments North America

Santa Cruz, CA USA

Tel: +1 800 227 8074 (USA and Canada, only)
+1 831 458 3900

solutions@flukeprocessinstruments.com

Fluke Process Instruments Europe

Berlin, Germany

Tel: +49 30 478 0080

info@flukeprocessinstruments.de

Fluke Process Instruments China

Beijing, China

Tel: +86 10 6438 4691

info@flukeprocessinstruments.cn

Worldwide Service

Fluke Process Instruments offers services, including repair and calibration. For more information, contact your local office.

www.flukeprocessinstruments.com

WARRANTY

The manufacturer warrants this product to be free from defects in material and workmanship under normal use and service for a period of two years from date of purchase except as hereinafter provided. This warranty extends only to the original purchaser. This warranty shall not apply to fuses or batteries. Factory calibration is warranted for a period of one year. The warranty shall not apply to any product that has been subject to misuse, neglect, accident, or abnormal conditions of operation or storage. Should the manufacturer be unable to repair or replace the product within a reasonable amount of time, purchaser's exclusive remedy shall be a refund of the purchase price upon return of the product.

In the event of failure of a product covered by this warranty, the manufacturer will repair the instrument when it is returned by the purchaser, freight prepaid, to an authorized Service Facility within the applicable warranty period, provided the manufacturer's examination discloses to its satisfaction that the product was defective. The manufacturer may, at its option, replace the product in lieu of repair. With regard to any covered product returned within the applicable warranty period, repairs or replacement will be made without charge and with return freight paid by the manufacturer, unless the failure was caused by misuse, neglect, accident, or abnormal conditions of operation or storage, in which case repairs will be billed at a reasonable cost. In such a case, an estimate will be submitted before work is started, if requested.

THE FOREGOING WARRANTY IS IN LIEU OF ALL OTHER WARRANTIES, EXPRESSED OR IMPLIED, INCLUDING BUT NOT LIMITED TO ANY IMPLIED WARRANTY OF MERCHANTABILITY, FITNESS, OR ADEQUACY FOR ANY PARTICULAR PURPOSE OR USE. THE MANUFACTURER SHALL NOT BE LIABLE FOR ANY SPECIAL, INCIDENTAL OR CONSEQUENTIAL DAMAGES, WHETHER IN CONTRACT, TORT, OR OTHERWISE.

Content

1 Safety Instructions	8
2 Description	10
3 Technical Data	11
3.1 PARAMETERS.....	11
3.2 OPTICAL DIAGRAM.....	13
3.3 SCOPE OF DELIVERY.....	14
4 Basics	15
4.1 MEASUREMENT OF INFRARED TEMPERATURE.....	15
4.2 DISTANCE AND SPOT SIZE.....	16
4.3 AMBIENT TEMPERATURE.....	16
4.4 ATMOSPHERIC QUALITY.....	16
4.5 ELECTRICAL INTERFERENCE.....	17
4.6 EMISSIVITY OF TARGET OBJECT.....	17
5 Install and Operation	18
5.1 DIMENSIONS OF SENSOR.....	18
5.2 MECHANICAL INSTALLATION.....	19
5.3 CABLE.....	19
5.4 WIRE CONNECTION.....	20
5.4.1 Analog output.....	20
5.4.2 Alarm output.....	20
5.5 LED INDICATOR AND BLINK MODE.....	21
6 Software	22
7 Accessories	23
7.1 OVERVIEW.....	23
7.2 FIXED MOUNTING BRACKET.....	24
7.3 ADJUSTABLE MOUNTING BRACKET.....	25
7.4 AIR PURGE COLLAR.....	26
7.5 RIGHT ANGLE MIRROR.....	27
7.6 PROTECTIVE WINDOW.....	28
8 Programming	29
8.1 GENERAL COMMAND STRUCTURE.....	29
8.2 DEVICE SETUP.....	30
8.2.1 Temperature Calculation.....	30
8.2.2 Post Processing.....	30

8.3 DYNAMIC DATA.....	30
8.4 DEVICE CONTROL	31
8.4.1 <i>Output for target temperature</i>	31
8.4.2 <i>Analog output, scaling</i>	31
8.4.3 <i>Alarm output</i>	31
8.4.4 <i>Factory default values</i>	32
9 Maintenance	33
9.1 TROUBLESHOOTING MINOR PROBLEMS	33
9.2 ERROR CODES.....	34
9.3 AUTOMATIC ERROR INDICATION	34
9.4 CLEANING THE LENS	34
10 Appendix	36
10.1 DETERMINATION OF EMISSIVITY.....	36
10.2 TYPICAL EMISSIVITY VALUES.....	36
10.3 COMMAND SET	43

1 Safety Instructions

This document contains important information, which should be kept at all times with the instrument during its operational life. Other users of this instrument should be given these instructions with the instrument. Eventual updates to this information must be added to the original document. The instrument can only be operated by trained personnel in accordance with these instructions and local safety regulations.

Acceptable Operation

This instrument is intended only for the measurement of temperature. The instrument is appropriate for continuous use. The instrument operates reliably in demanding conditions, such as in high environmental temperatures, as long as the documented technical specifications for all instrument components are adhered to. Compliance with the operating instructions is necessary to ensure the expected results.

Unacceptable Operation

The instrument should not be used for medical diagnosis.

Replacement Parts and Accessories

Use only original parts and accessories approved by the manufacturer. The use of other products can compromise the operational safety and functionality of the instrument.

Instrument Disposal



Disposal of old instruments should be handled according to professional and environmental regulations as electronic waste.

Safety Instructions

Operating Instructions

The following symbols are used to highlight essential safety information in the operation instructions:



Helpful information regarding the optimal use of the instrument.



Warnings concerning operation to avoid instrument damage and personal injury.

Pay particular attention to the following safety instructions.



Incorrect use of 110 / 230 V electrical systems can result in electrical hazards and personal injury. All instrument parts supplied with electricity must be covered to prevent physical contact and other hazards at all times.

2 Description

The CM miniature infrared sensors are high performance noncontact infrared temperature measurement systems. They measure the amount of energy emitted from an object accurately and repeatedly and convert the energy into temperature signal.

The following analog outputs are available by different model:

- 0 to 5 Volt
- J thermocouple
- K thermocouple

The LED on the back of CM shows the status of units.

3 Technical Data

3.1 Parameters

Temperature range -20 to 500°C (-4 to 932°F)

Spectral response 8 to 14 μm

Thermal Parameters

Accuracy¹ (Digital and Voltage) $\pm 1.5\%$ of reading or $\pm 2^\circ\text{C}^2$
whichever is greater

Accuracy³ (TC) $\pm 1.5\%$ of reading $\pm 2^\circ\text{C}$ or $\pm 4^\circ\text{C}^4$
whichever is greater

Repeatability (Digital and Voltage) $\pm 0.5\%$ of reading or $\pm 1^\circ\text{C}$
whichever is greater

Repeatability (TC) $\pm 0.5\%$ of reading $\pm 1^\circ\text{C}$ or $\pm 2^\circ\text{C}$
whichever is greater

Response time (95%) 150 ms

Temperature resolution 0.1°C (0.2°F)

Emissivity 0.100 to 1.100 (software controlled)

Transmissivity 0.100 to 1.000 (software controlled)

Electrical Parameters

Power 24 VDC $\pm 20\%$ @ 20 mA

Analog Output 0 to 5 V or TCJ or TCK output

¹ for ambient temperature 23°C (73°F) $\pm 5\text{ K}$, $e = 0.95$ and calibration geometry

² $\pm 3.5^\circ\text{C}$ for $T_{\text{meas}} < 0^\circ\text{C}$ (32°F)

³ for ambient temperature 23°C (73°F) $\pm 5\text{ K}$, $e = 0.95$ and calibration geometry

⁴ $\pm 5.5^\circ\text{C}$ for $T_{\text{meas}} < 0^\circ\text{C}$ (32°F)

Digital Output	Two-way RS232 digital output 9600 baud, 8 data bits, 1 stop bit, no parity, no flow control
Alarm Output	Transistor, 24 VDC @ 20 mA



RS232 TxD and Alarm output share one single wire. Either can be selected by DataTemp software or ASCII command!

General Parameters

Environmental rating	IP65 (NEMA-4x)
Ambient operating range	-10 to 70°C (14 to 158°F)
Storage temperature	-20 to 85°C (-4 to 185°F)
Dimensions	Ø ¾", length: 94 mm (3.7 in)
Weight	< 200 g (7.1 oz)

3.2 Optical Diagram

The optical diagrams indicate the target spot diameter at any given distance between the target object and the sensing head.

All target spot sizes indicated in the optical diagrams are based on 90% energy.

Optical resolution 13:1 @ 150 mm (90% energy)

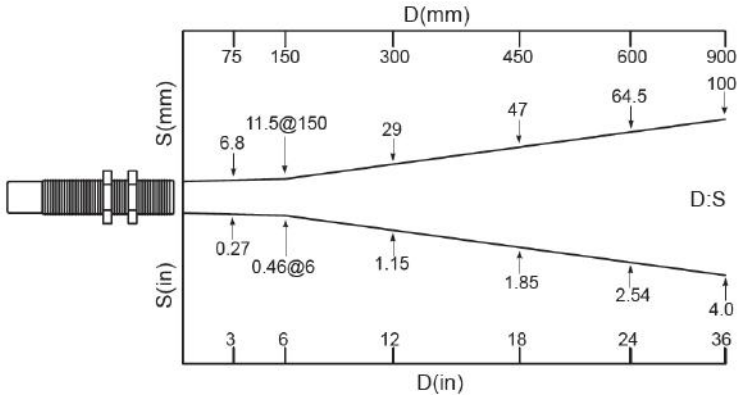

Figure 1 : Optical diagram

Calculating the Target Spot Size

To calculate the target spot size from two known points within an optical diagram the following formula can be used:

$$S_x = S_n + \left[\frac{(D_x - D_n)}{(D_f - D_n)} \cdot (S_f - S_n) \right]$$

S_x = unknown diameter of target spot

S_n = smallest known diameter of target spot

S_f = greatest known diameter of target spot

D_x = distance to unknown target spot

D_n = distance to smaller known target spot

D_f = distance to greater known target spot

3.3 Scope of Delivery

- Sensor
- 2 mounting nuts
- Support software CD
- Quickstart Guide

4 Basics

4.1 Measurement of Infrared Temperature

Everything emits an amount of infrared radiation according to its surface temperature. The intensity of the infrared radiation changes according to the temperature of the object. Depending on the material and surface properties, the emitted radiation lies in a wavelength spectrum of approximately 1 to 20 μm . The intensity of the infrared radiation (“heat radiation”) is dependent on the material. For many substances this material-dependent constant is known. It is referred in Section 10.2 [Typical Emissivity Values](#) on page 36.

Infrared thermometers are optical-electronic sensors. These sensors are able to detect “radiation of heat”. Infrared thermometers are made up of a lens, a spectral filter, a sensor, and an electronic signal-processing unit. The task of the spectral filter is to select the wavelength spectrum of interest. The sensor converts the infrared radiation into an electrical parameter. The connected electronics generate electrical signals for further analysis. As the intensity of the emitted infrared radiation is dependent on the material, the required emissivity can be selected on the sensor.

The biggest advantage of the infrared thermometer is its ability to measure in the absence of contact. Consequently, surface temperatures of moving or hard to reach objects can easily be measured.

4.2 Distance and Spot Size

The desired spot size on the target will determine the maximum measurement distance and the necessary focus length of the optical module. To avoid erroneous readings the target spot size must contain the entire field of view of the sensor. Consequently, the sensor must be positioned so the field of view is the same as or smaller than the desired target size.

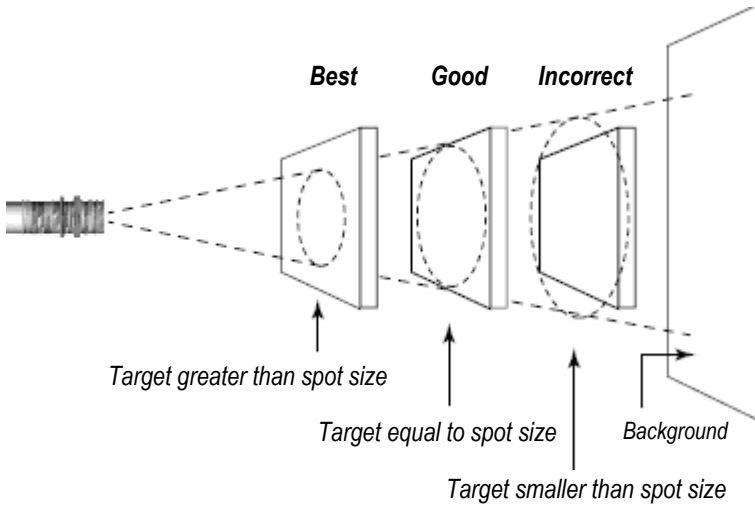

Figure 2: Proper Sensor Placement

4.3 Ambient Temperature

The sensing head should work under ambient operating range in accordance to section 3.1 [Parameters](#), page 11.

4.4 Atmospheric Quality

In order to prevent damage to the lens and erroneous readings, the lens should always be protected from dust, smoke, fumes, and other contaminants. For this purpose an air purge collar is available. You should only use oil free, clean “instrument” air.

4.5 Electrical Interference

To minimize electrical or electromagnetic interference, follow these precautions:

- Mount the sensor as far away as possible from possible sources of interference such as motorized equipment producing large step load changes.
- Ensure a fully insulated installation of the sensor (Avoid ground loops!).
- Make sure the shield wire in the sensor cable is earth grounded at one location.

4.6 Emissivity of Target Object

Determine the emissivity of the target object as described in appendix 10.1 [Determination of Emissivity](#). If emissivity is low, measured results could be falsified by interfering infrared radiation from background objects (such as heating systems, flames, fireclay bricks, etc. close beside or behind the target object). This type of problem can occur when measuring reflecting surfaces and very thin materials such as plastic films and glass.

This measuring error when measuring objects with low emissivity can be reduced to a minimum if particular care is taken during installation, and the sensing head is shielded from these reflecting radiation sources.

5 Install and Operation

5.1 Dimensions of Sensor



All sensors and accessories are supplied with 3/4-16 UNF-2A or M18x1 thread.

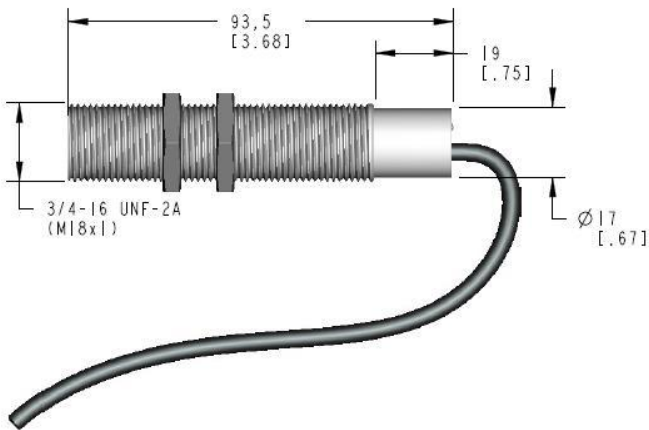

Figure 3: Dimensions of sensor

Install and Operation

5.2 Mechanical Installation

All sensors come with a 1.0 m (3.3 ft) cable or 3.0 m (9.8 ft) and 2 mounting nuts. You can mount the sensor in brackets or cutouts of your own design, or you can use the mounting bracket accessories.



Figure 4: Sensor with fixed mounting bracket

5.3 Cable

The color code of the cable and 6 conductors are shown in the following table:

	8 Outer Jacket	1 Power +	2 Power -**	3 Rx D	4 Tx D/ Alarm	5 TC+/ mV+	6 TC-/ mV-	7 Shield
J	brown	orange	black	blue	violet	white	red	
K	yellow					yellow	red	
0 to 5 V	grey					yellow	brown	

** Die RS232's Ground must be connected to Power-

Table 1: Sensor Wiring Color Code

5.4 Wire Connection

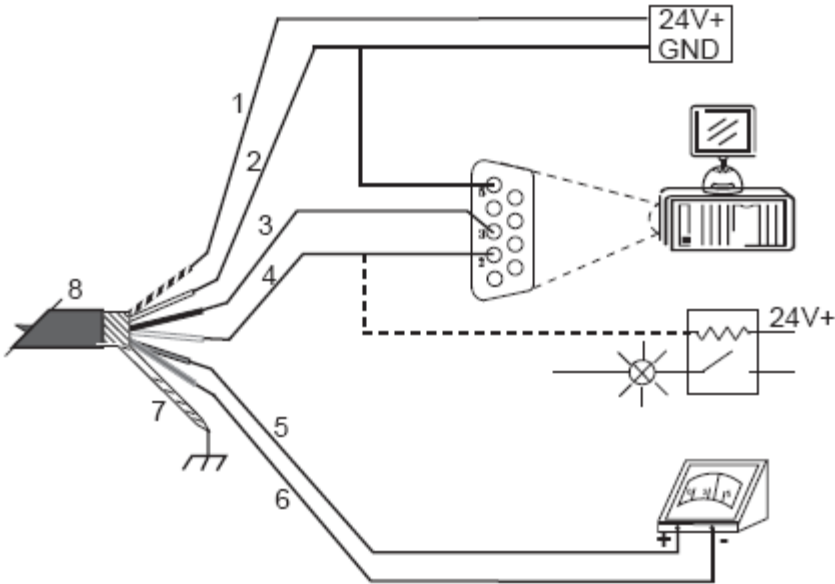

Figure 5: Connection diagram

5.4.1 Analog output





There are 3 models available: 0 to 5 V, TCJ, TCK.
 Minimum load impedance for 0 to 5 V output should be 50 k Ω .
 Inner impedance of TC output circuit is 100 Ω .

5.4.2 Alarm output

RS232 TxD and alarm output share one single wire. Either can be selected by the DataTemp software or RS232 command. When alarm mode is active, the CM can receive command from a PC via RS232, but can't respond to the PC. RS232 TxD can work normally after the alarm output is switched off by command K=0, see Section 10.3 [Command Set](#). If unit is set by DataTemp software, alarm output is valid only after the unit is restarted.

5.5 LED indicator and blink mode

You can easily find the unit health status by the following LED blink mode:

status	LED-blink	LED-status
normal	slow blink 1	
alarm	fast blink	
out of range	double blink	
unstable*	slow blink 2	
alarm fault**	always lighting	

* unstable is typically caused by head ambient temperature fluctuations due to initial warm up or thermal shock situations.

** alarm fault indicates the input of sensor's alarm port is over current.

Table 2: LED blink mode

6 Software

Raytek DataTemp Multidrop software allows the configuration and monitoring of CM sensor operating parameters, such as:

- Emissivity
- Transmissivity
- Averaging
- Peak hold
- Valley hold
- Temperature scale of analog output
- Alarm temperature value
- 1 point field calibration offset
- Alarm output

Refer to DataTemp software online help for more detail.

Notes for CM sensors:

1. Use the Temperature unit in Degree C for field calibration, if in Degree F, there is no effect.
2. CM shares the alarm line with the RS232 Tx/D and the alarm function will be temporarily turned off and changed to RS232 mode when connecting to the DataTemp software. After re-powering the sensor without connecting to the DataTemp software, the alarm mode will function normally.

7 Accessories

7.1 Overview

Fixed Mounting Bracket	XXXCIACFB
Adjustable Mounting Bracket	XXXCIADJB
Air Purge Collar	XXXCMACAP metrical: XXXCMACAPM
Right Angle Mirror	XXXCMACRA metrical: XXXCMACRAM
Protective Window	XXXCMACPW metrical: XXXCMACPWM

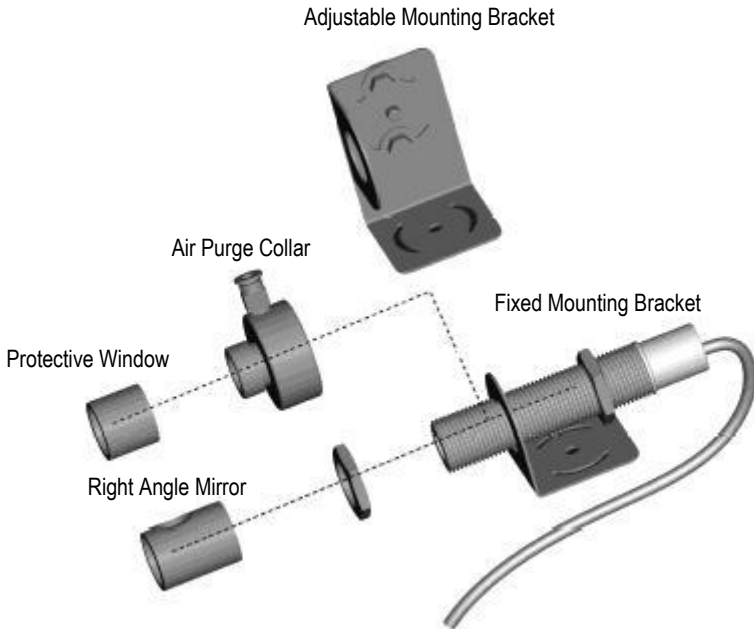

Figure 6: Overview of available accessories

7.2 Fixed Mounting Bracket

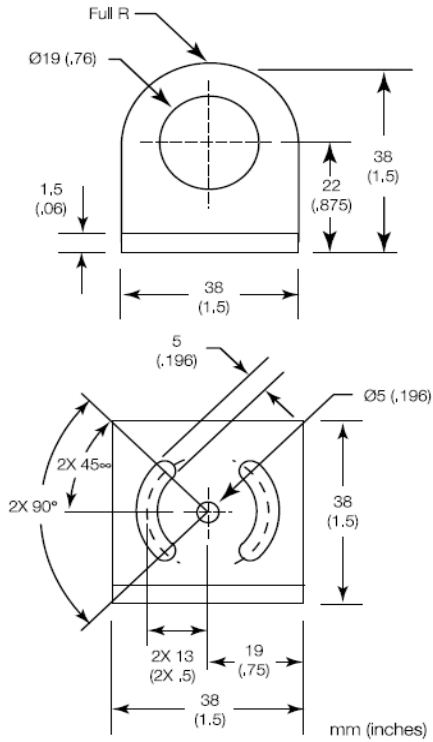

Figure 7: Dimensions of Fixed Mounting Bracket

7.3 Adjustable Mounting Bracket

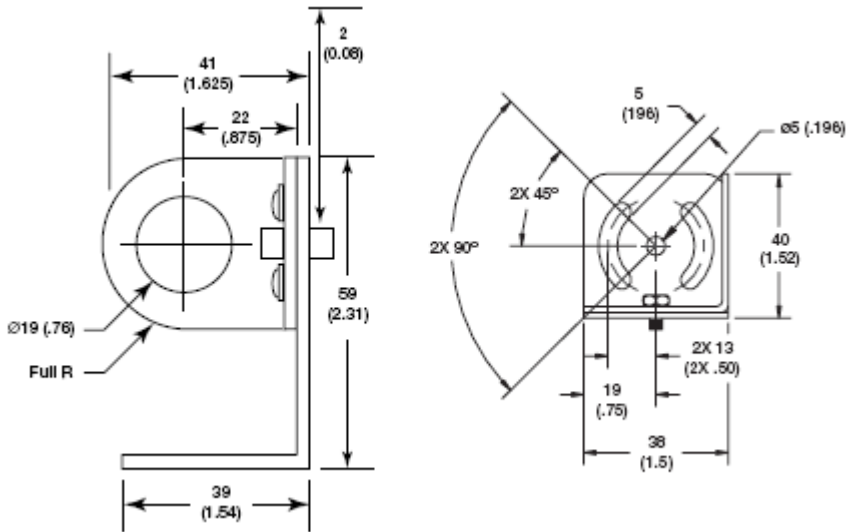

Figure 8: Dimensions of Adjustable Mounting Bracket

7.4 Air Purge Collar

The Air Purge Collar is used to keep dust, moisture, airborne particles, and vapors away from the lens. It can be mounted before or after the bracket. It has the push-in fitting. A 4 mm (0.16 in) outside diameter plastic tubing is recommended to connect the fitting. Air flows into the fitting and out the front aperture. The pressure of air should be 0.6 to 1 bar (8.7 to 15 PSI). Clean, oil free air is recommended.

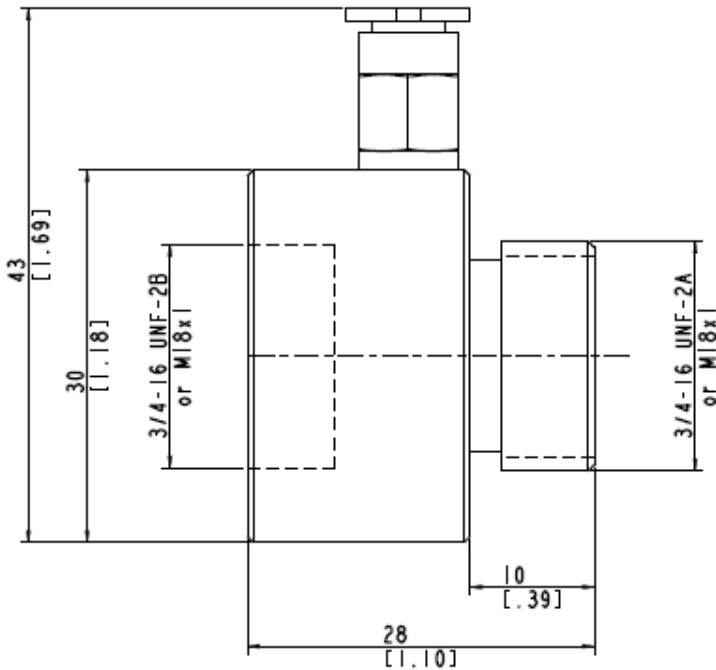

Figure 9: Dimensions of Air Purge Collar

7.5 Right Angle Mirror

The Right Angle Mirror is used to turn the field of view by 90° against the sensor axis. It is recommended when space limitations or excessive radiation do not allow for direct alignment of the sensor to the target. The mirror must be installed after the bracket and after the Air Purge Collar and screwed in fully. In dusty or contaminated environments, air purging is required to keep the mirror surface clean.

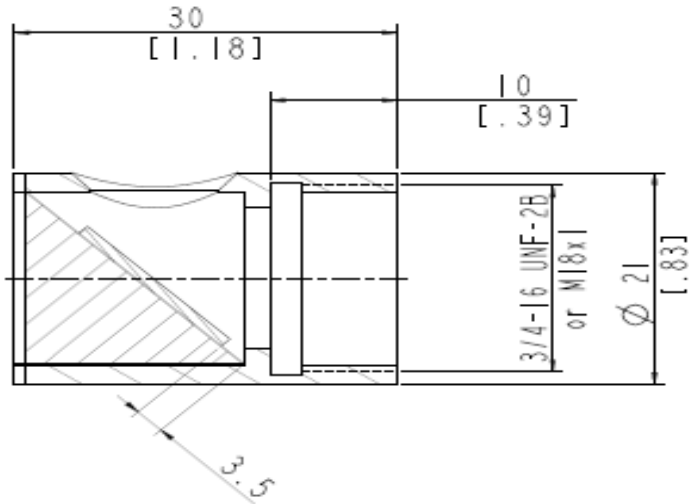

Figure 10: Dimension of Right Angle Mirror



When using the Right Angle Mirror, adjust the emissivity or transmissivity settings downward by 5%. For example, for an object with an emissivity of 0.65, you adjust the value down to 0.62. Or, you can keep the emissivity 0.65 and adjust the transmissivity from 1.0 to 0.95. This correction accounts for energy losses in the mirror.

7.6 Protective Window

The protective window comes with Silicon as window material.

Determination of transmissivity of an unknown protective window:

If transmissivity of the measuring screen is not indicated on the data sheet, you can also determine the transmissivity yourself. Please proceed as follows:

1. Measure the temperature of the target object with the sensing head, without using the protective window. Note correct setting of emissivity.
2. Insert the protective window in the sensing head.
3. Adjust the transmissivity in the software until the same temperature is displayed, as it was determined without the protective window.

8 Programming

8.1 General Command Structure

Requesting a parameter

?E<CR> “?” is the command for “Request”
 “E” is the parameter requested
 <CR> (carriage return, 0Dh) is closing the request.

Remark: It is possible to close with <CR> <LF> (0Dh 0Ah), but <LF> (0Ah) is not necessary.

Setting a parameter (Poll Mode)

The parameter will be stored into the device flash memory.

E=0.975<CR> “E” is the parameter to be set
 “=” is the command for “set a parameter”
 “0.975” is the value for the parameter
 <CR> (carriage return, 0Dh) is closing the request

Remark: It is possible to close with <CR> <LF> (0Dh 0Ah), but <LF> (0Ah) is not necessary.

Setting a parameter without writing it into the device flash memory.

This function is for test purposes only.

E#0.975<CR> “E” is the parameter to be set
 “#” is the command for “set parameter without writing it into
 the Flash”
 “0.975” is the value for the parameter
 <CR> (carriage return, 0Dh) is closing the request.

Remark: It is possible to close with <CR> <LF> (0Dh 0Ah), but <LF> (0Ah) is not necessary.

Device response format:

!E0.975<CR><LF> “!” is the parameter for “Answer”
 “E” is the Parameter
 “0.975” is the value for the parameter

<CR> <LF> (0Dh 0Ah) is closing the answer.

Error message: *Syntax Error *** is the character for "Error".

8.2 Device Setup

8.2.1 Temperature Calculation

U=C Physical Unit for the temperature value

E=0.950 Emissivity setting

XG=1.000 Setting for transmission

For the calculation of the temperature value, it is possible to set an offset (relative number to be added to the temperature value).

DO=-0.3 Offset adjustment -0.3 for the temperature signal

8.2.2 Post Processing

The following parameters can be set to determine the post-processing mode

P=5 maximum hold, hold time: 5 sec

F=12.5 minimum hold, hold time: 12.5 sec

G=10 averaging, average time (90%): 10 sec

8.3 Dynamic Data

To request the dynamic data, the following commands are available:

?T Target temperature

?I Detector ambient temperature

?XJ Temperature of Thermocouple cold end (only valid for TC)

?Q energy value of the target temperature

To check for resets (e.g. power shut down) use the command XI. Notice, after a reset the unit is re- initialized.

?XI asks for the reset status

!XI0 no reset occurred

!XI1 a reset occurred, new initialization of the unit

XI=0 sets the reset status back to 0

8.4 Device Control

8.4.1 Output for target temperature

The output can provide a predefined value of full analog range when signal output is 0 ... 5 V.

?XO	Request for the output mode
O=25	output of a constant voltage at 1.25 V (25% of 0 ... 5 V)
O=255	switches back to the temperature controlled output

8.4.2 Analog output, scaling

According to the temperature range of the model, it is possible to set the maximum voltage value according to a temperature value (e.g., the maximum voltage 5 V shall represent 200°C). The same setting is possible for the minimum value.

H=500	the maximum voltage value is set to 500°C
L=0	the minimum voltage value is set to 0°C



You cannot set these values for thermocouple output. The minimum span between the maximum / minimum settings is 20 K.

8.4.3 Alarm output

The alarm output can be set to N.C. (relay contacts are closed while in home position) or N.O. (relay contacts are open while in home position). The alarm output can be activated by:

- Internal sensing head temperature
- Target temperature

K=0	alarm output disabled
K=4	Sensor head ambient temperature lower than threshold, relay N.O.
K= 2, XS=125.3	Target temperature lower than threshold, relay N.O., threshold setting to 125.3°C (if U=C is set)

8.4.4 Factory default values

It is possible to reset the unit to the original factory default values.

XF factory default values will be set

9 Maintenance

Our customer service representatives are always at your disposal for any questions you might have. This service includes any support regarding the proper application of your infrared measuring system, calibration or the solution to customer-specific solutions as well as repair.

In many cases your problems will be application-specific and can possibly be solved over the telephone. So, if you need to return equipment to us, please contact our Service Department before doing so. See phone and fax numbers at the beginning of this document.

9.1 Troubleshooting Minor Problems

Symptom	Possible Cause	Solution
No Output	Cable disconnected	Check Cable Connections
Erroneous Temperature	Cable damaged	Check Cable
Erroneous Temperature	Field of View Obstructed	Remove the Obstruction
Erroneous Temperature	Lens Dirty	Clean the Lens
Erroneous Temperature	Wrong Emissivity Setting	Correct the Setting (Appendix)
Temperature Fluctuates	Wrong Signal Processing	Correct Peak, Valley, or Average Settings
Temperature Fluctuates	Sensor not grounded	Check Wiring/Grounding

Table 3: Troubleshooting

9.2 Error Codes

Output	Error Code Description
T>>>>>	Temperature over range
T<<<<<	Temperature under range

Table 4: Error Codes (via RS232)

9.3 Automatic Error Indication

The automatic error indication (alarm output) shall warn the user and guarantee a secure output in the event of a system error. In the first place, however, its task is to switch the system off in case of a faulty setup or a defect in the sensing head or in the electronic circuits.



Never rely exclusively on the automatic error indication when monitoring critical heating processes. It is strongly recommended to take additional safety measures.

9.4 Cleaning the Lens

Care should be taken to keep the lens clean. Any foreign matter on the lens will affect the accuracy of the measurements. Be sure to take care when cleaning the lens. Please observe the following:

1. Blow off loose particles with clean air.
2. Gently brush off remaining particles with a soft camel hair brush.
3. To remove any severe contamination, use a clean, soft cloth dampened with distilled water. In any case, do not scratch the lens surface!

For fingerprints or other grease, use any of the following:

- Denatured alcohol
- Ethanol
- Kodak lens cleaner

Apply any of the above to the lens. Wipe gently with a clean, soft cloth until you see colors on the lens surface, then allow to air dry. Never wipe the surface

Maintenance

dry - this may scratch the surface. If the lens is contaminated with silicones (e.g. from hand creams), clean it carefully using Hexane. Allow the lens to air dry.



Do not use any ammonia or any cleaners containing ammonia to clean the lens. This may result in permanent damage to the lens' surface.

10 Appendix

10.1 Determination of Emissivity

Emissivity is a measure of an object's ability to absorb and emit infrared energy. It can have a value between 0 and 1.0. For example, a mirror has an emissivity of 0.1, while the so-called "Blackbody" reaches an emissivity value of 1.0. If a higher than actual emissivity value is set, the output will read low, provided the target temperature is above its ambient temperature. For example, if you have set 0.95 and the actual emissivity is 0.9, the temperature reading will be lower than the true temperature.

An object's emissivity can be determined by one of the following methods:

1. Determine the actual temperature of the material using an RTD (PT100), a thermocouple, or any other suitable method. Next, measure the object's temperature and adjust emissivity setting until the correct temperature value is reached. This is the emissivity for the measured material.
2. For relatively low temperatures (up to 260°C, 500°F), place a plastic sticker on the object to be measured. This sticker should be large enough to cover the target spot. Next, measure the sticker's temperature using an emissivity setting of 0.95. Finally, measure the temperature of an adjacent area on the object and adjust the emissivity setting until the same temperature is reached. This is the emissivity for the measured material.
3. If possible, apply flat black paint to a portion of the surface of the object. The emissivity of the paint must be above 0.98. Next, measure the temperature of the painted area using an emissivity setting of 0.98. Finally, measure the temperature of an adjacent area on the object and adjust the emissivity until the same temperature is reached. This is the emissivity for the measured material.

10.2 Typical Emissivity Values

The following table provides a brief reference guide for determining emissivity and can be used when one of the above methods is not practical. Emissivity values shown in the table are only approximate, since several parameters may affect the emissivity of a material. These include the following:

Appendix

1. Temperature
2. Angle of measurement
3. Geometry (plane, concave, convex)
4. Thickness
5. Surface quality (polished, rough, oxidized, sandblasted)
6. Spectral range of measurement
7. Transmissivity (e.g. thin films plastics)

METAL			
Material	Emissivity/ Spectral range		
	3.9 μm	5 μm	8 – 14 μm
Aluminum			
Unoxidized			0.02-0.1
Oxidized			0.2-0.4
Alloy A3003, Oxidized			0.3
Roughened			0.1-0.3
Polished			0.02-0.1
Lead			
Polished			0.05-0.1
Rough			0.4
Oxidized			0.2-0.6
Chromium			0.02-0.2
Iron			
Oxidized			0.5-0.9
Unoxidized			0.05-0.2
Rusted			0.5-0.7
Molten			—
Iron, Cast			
Oxidized			0.6-0.95
Unoxidized			0.2
Molten			0.2-0.3
Iron, Wrought			
Dull			0.9
Gold			0.01-0.1
Haynes			
Alloy			0.3-0.8
Inconel			
Oxidized			0.7-0.95
Sandblasted			0.3-0.6
Electropolished			0.15
Copper			
Polished			0.03
aufgeraut			0.05-0.1

Appendix

METAL			
Material	Emissivity/ Spectral range		
	3.9 μm	5 μm	8 – 14 μm
oxidiert			0.4-0.8
Magnesium			0.02-0.1
Brass			
Polished			0.01-0.05
Burnished			0.3
Oxidized			0.5
Molybdenum			
Oxidized			0.2-0.6
Unoxidized			0.1
Monel (Ni-Cu)			0.1-0.14
Nickel			
Oxidized			0.2-0.5
Electrolytic			0.05-0.15
Platinum			
Black			0.9
Mercury		Mercury	0.05-0.15
Silver			0.02
Steel			
Cold-Rolled			0.7-0.9
Ground Sheet			0.4-0.6
Polished Sheet			0.1
Molten			—
Oxidized			0.7-0.9
Stainless			0.1-0.8
Roughened			0.05-0.1
Oxidized			0.4-0.8
Titanium			
Polished			0.05-0.2
Oxidized			0.5-0.6
Tungsten			0.03
Polished			0.03-0.1
Zinc			
Oxidized			0.1

METAL			
Material	Emissivity/ Spectral range		
	3.9 μm	5 μm	8 – 14 μm
Polished			0.02
Tin (Unoxidized)			0.05

Table 5: Typical Emissivity Values

NON-METAL MATERIAL			
Material	Emissivity/ Spectral range		
	3.9 μm	5 μm	8 – 14 μm
Asbestos			0.95
Asphalt			0.95
Basalt			0.7
Concrete			0.95
Ice			0.98
Paint (non-al.)			0.9-0.95
Gypsum			0.8-0.95
Glass			
Plate			0.85
„Gob“			—
Rubber			0.95
Wood, Natural			0.9-0.95
Limestone			0.98
Karborund			0.9
Ceramic			0.95
Gravel			0.95
Carbon			
Unoxidized			0.8-0.9
Graphite			0.7-0.8
Clay			0.95
Paper (any color)			0.95
Plastic (opaque, over 20 mils)			0.95
Salz			0.9-0.98
Sand			0.9
Snow			0.9
Cloth			0.95
Water			0.93

Table 6: Typical Emissivity Values Non- Metal Material

To optimize surface temperature measurements, consider the following guidelines:

- Determine the object emissivity using the instrument that will also be used for the measurements.
- Avoid reflections by shielding the object from surrounding temperature sources.
- For higher temperature objects, use instruments with the shortest wavelength possible.
- For translucent materials, such as plastic foils or glass, assure that the background is uniform and lower in temperature than the object.
- You should place the sensor perpendicular to the object's surface (if possible) or at any angle from the target up to 30°!

Appendix

10.3 Command Set

P ... Poll, B ... Burst, S ... Set, N ... Notification

FORMATSET					
Description	Char	Format	P	S	Example
Poll parameter	?	?X	√		?T
Set parameter	=	X=...		√	E=0.85
Set without Save	#	X#		√	E#0.85

FORMAT RESPONSE					
Description	Char	Format	P	S	Example
Acknowledge	!	!XXX			!T020.0
Error message	*				*Syntax error

COMMAND LIST						
Description	Char	Format	P	S	Legal values	Factory default
Device adjustment gain**	DG	n.nnnn	√	√	0.8000 ... 1.2000	1
Device adjustment offset **	DO	nn.n	√	√	-20.0 ... +20.0°C	0
Device special Info.	DS	XXX	√		z.B. !DSRAY	DSRAY
Emissivity internal	E	n.nnn	√	√	0.100 ... 1.100	0.95
Valley hold time	F	nnn.n	√	√	0.000 ... 998.9 s (999 = infinite)	0
Average time	G	nnn.n	√	√	0.100 ... 999 s	0
Top of mV range	H	nnnn.n	√	√	0 ... 500°C	500
Sensor/head ambient	I	nnn.n	√		In current scale (°C/°F)	
Relay alarm output control	K	n	√	√	0=Alarm Off 1=Alarm On 2= Target, normal open 3= Target, normal close 4= Head, normal open 5= Head, normal close 6= Over current protect*	
Bottom of mV range	L	nnnn.n	√	√	-20 ... 480°C	-20
Output voltage***	O	nnn	√	√	0-100=% of full range 255=controlled by unit	

Peak hold time	P	nnn.n	√	√	0.100~998.9 secs (999=infinite)	0
Power	Q	nnnnn	√			
Target temperature	T	nnnn.n	√		In current scale (°C / °F)	
Temperature unit	U	X	√	√	C / F	C
Device bottom range limit	XB	nnnn.n	√		-20°C	-20
Restore factory defaults	XF			√		
Transmission	XG	n.nnn	√	√	0.100 ... 1.000	1
Device high range limit	XH	nnnn.n	√		500°C	500
Sensor initialization	XI	n	√	√	1 = after RESET, 0 = if XI = 0	
TC cold end temperature	XJ	nnn.n	√		In current scale (°C / °F)	
Analog output mode	XO	n	√	√	1 = 0 ... 5 V 2 = TCJ 3 = TCK	
FW revision	XR		√		e.g. 1.000	
Setpoint/Relay function	XS	nnnn.n	√	√	-17.2 ... 497.2°C	497.2
Unit identification	XU	nnnn.n	√		e.g. !CMLTV	
Serial number	XV		√		e.g. 00012345	
* Poll only						
** only available when unit is in °C mode						
*** only available when unit is in mV mode						

Table 7: Command set