

FLZ 600 | FLZ 610

HYGROSTAT | HYGROSTAT-THERMOSTAT COMBINATION DEVICE

Hygrostats from the FLZ series switch on control cabinet heaters or filterfans when a preset relative humidity is exceeded. The relative humidity is kept above the dew point and the condensation of water on electrical components and the corrosion of unprotected sheet metal is prevented. The electronic combination device unites thermostat and hygrostat in one housing and, at the same time, monitors the relative humidity and the temperature independently of each other.



PRODUCT	FLZ 600		FLZ 610	
ARTICLE NO.	17207000000		17218100000	UNIT
DATA				
Device implementation	mechanical hygrostat		electronic hygrostat-thermostat combination device	
Rated voltage ±10%	N/A		AC 50/60	Hz
			230	V
Type of contact	changeover with spring contact		changeover/relay	
Switching difference	approx. 5 %		approx. 2 K ±1 K / approx. 4 % R.H. ±1 %	
Contact resistance	-		< 10	mΩ
Max. switching power value in brackets: inductive load at cos φ = 0.6	N.C.	24–250 V AC / 2 (0.2) A – min. 100 mA	240 V AC, 8 (3) A or 120 V AC, 8 (3) A	
	N.O.	24–250 V AC / 5 (0.2) A – min. 100 mA		
	DC	50 V, 1 A 75 V, 0.5 A min. 100 mA	-	
Setting range	40–90			% R.H.
Operating temperature	0 ... +60		0 ... +60	°C
System of protection	IP 30		IP 20	
Probe type	polyamide belt		-	
Suitable for the operation of	fan and heater			
Operating display	-		LED	
Type of mounting	snap fastening for 35 mm profile bars according to EN 60715			
Type of connection	screw terminal for cable cross-section 0.5 to 2.5 mm ²			
Colour	RAL 7035			
Weight	55		85	g

ACCESSORIES	ARTICLE NUMBER
Hygrostat	17207000000
Internal enclosure fan	18110000000

For additional models, options and voltages visit www.pfannenberg.com or contact us directly.



DIMENSIONS

mm	FLZ 600	FLZ 610
X	37	59
Y	60	80.5
Z	47	38

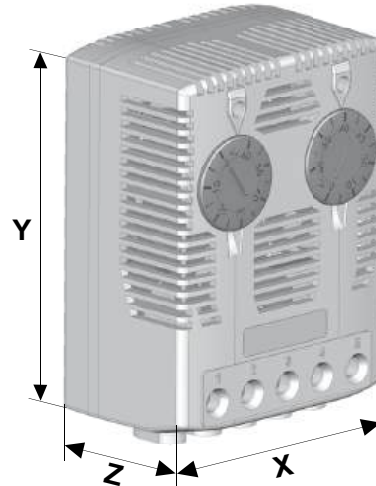

SCHEMATICS

FLZ 600

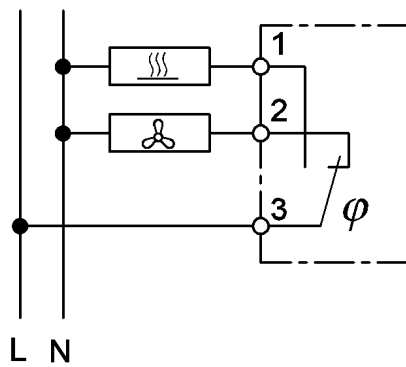

FLZ 610

