

GN 607.1

Steel / Stainless Steel

Short Indexing Plungers

Lock-Out



JW WINCO®
A Ganter Company

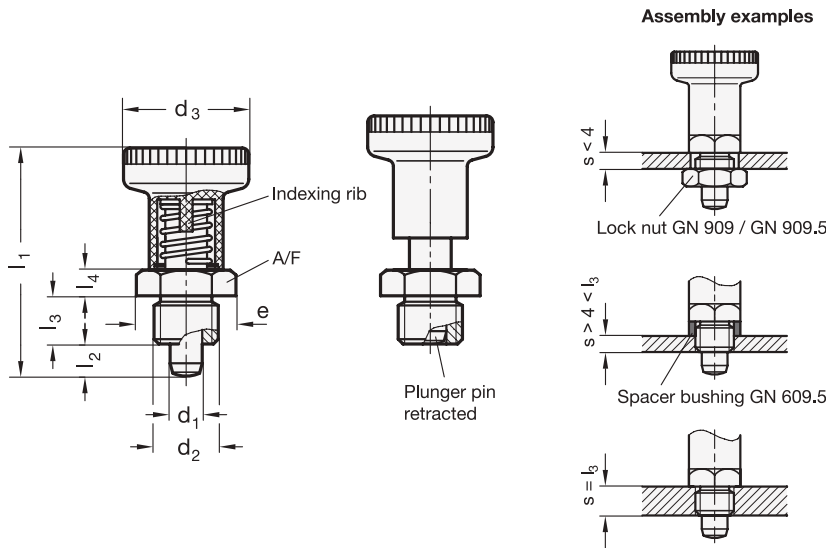

SS Stainless Steel

2 Type

- A** Without lock nut
- AK** With lock nut

Metric table

Dimensions in: millimeters - inches

d ₁ Pin -0.02 Bore H7	d ₂ Thread	d ₃	e ≈	l ₁	l ₂ ±0.5	l ₃ -0.15	l ₄	A/F	Spring load ≈ Steel		Stainless steel		Axial load
									Initial	End	Initial	End	
6 .24	M 12 x 1.5	25 .98	19.6 .77	45 1.77	6 .24	10 .39	5 .20	17 .67	11 N 2.47 lbf	28 N 6.29 lbf	9 N 2.02 lbf	25 N 5.62 lbf	400 N 89.92 lbf
8 .31	M 16 x 1.5	31 1.22	21.9 .86	54 2.13	8 .31	12 .47	6 .24	19 .75	15 N 3.37 lbf	29 N 6.52 lbf	13 N 2.92 lbf	26 N 5.85 lbf	500 N 112 lbf

Specification

- Threaded body
 - Steel, blackened finish **ST**
 - Plunger pin hardened
 - Stainless steel **NI**
 - European Standard No. 1.4305 (AISI 303)
 - Plunger pin chemically nickel plated
- Knob
 - Plastic
 - Technopolymer (Polyamide PA)
 - Temperature resistant up to 230 °F (110 °C)
 - Black, matte finish
 - Not removable
- Lock nut
 - Thin hexagon nut GN 909 / GN 909.5
 - Steel, blackened finish
 - Stainless steel
 - European Standard No. 1.4305 (AISI 303)
- RoHS compliant

Information

GN 607.1 short indexing plungers with lock-out are used for applications where the plunger pin needs to stay in its retracted position. To achieve this, the knob is rotated by 90 degrees after being retracted. A notch keeps the plunger in the retracted position.

The extremely thin GN 909 / GN 909.5 lock nuts increase the mounting options.

see also...

- *List of Indexing Plunger Types*
- *Locating Bushings GN 412.2 / GN 412.4*
- *Locating Bushings with Cone GN 412.3 / GN 412.5*
- *Spacer Bushings GN 609.5 (to Limit the Thread Length)*

How to order

GN607.1-6-A-ST

1	Pin diameter d ₁
2	Type
3	Material