

SEE DETAIL A

2X (Ø0.219)

SEE DETAIL B

0.075 REF

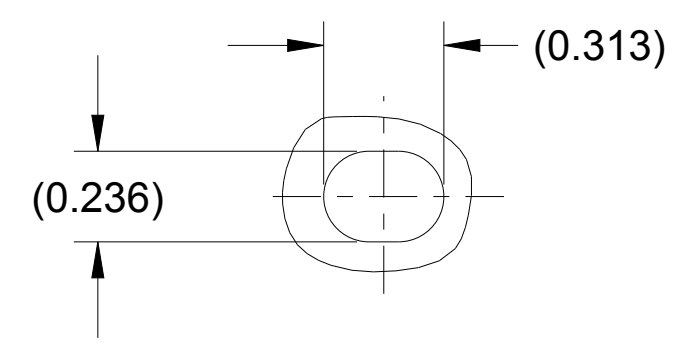

DETAIL A  
SCALE 2.000

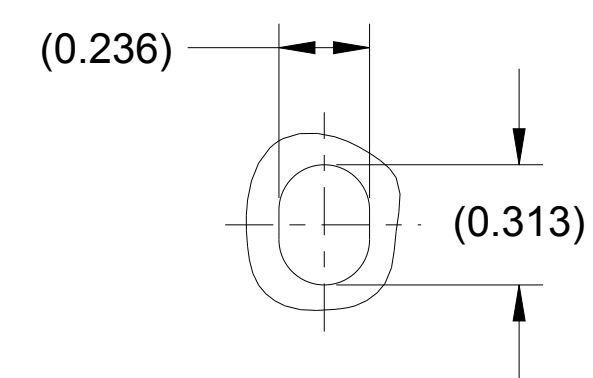

DETAIL B  
SCALE 2.000

- NOTES:  
 1. MATERIAL: 14 GAUGE STEEL  
 2. FINISH: POWDER COATED WHITE  
 3. DIMENSIONS APPLY AFTER POWDER COAT

				DEFAULT TOLERANCES DECIMAL .XX ± 0.03 .XXX ± 0.010 FRACTIONAL ± 1/16 ANGULAR ± 5°			MUM INDUSTRIES 8989 TYLER BLVD MENTOR, OHIO, U.S.A. (440) 269-8155 FAX (440) 269-8166		
				SCALE	1.000	SHEET	1 of 1	DRAWN BY	T.STOKES
				TITLE					PANEL-BACK-8X8-PS
				DATE		DRAWING NUMBER		REV	
A INITIAL RELEASE				BY	TLS	DATE	5-1-19	2019-058	
REV				DESCRIPTION		PNLB88PS-115		A	