

4

3

2

1

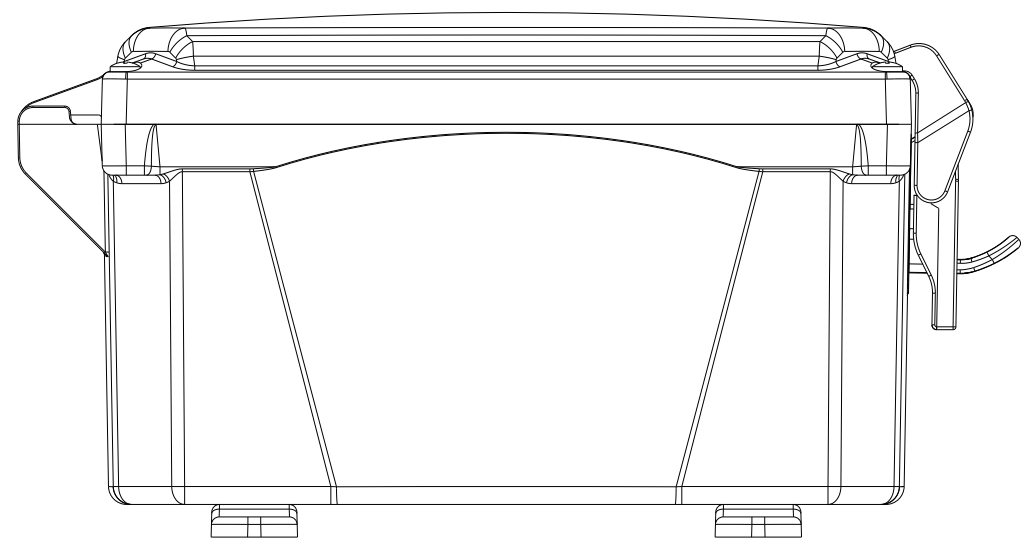
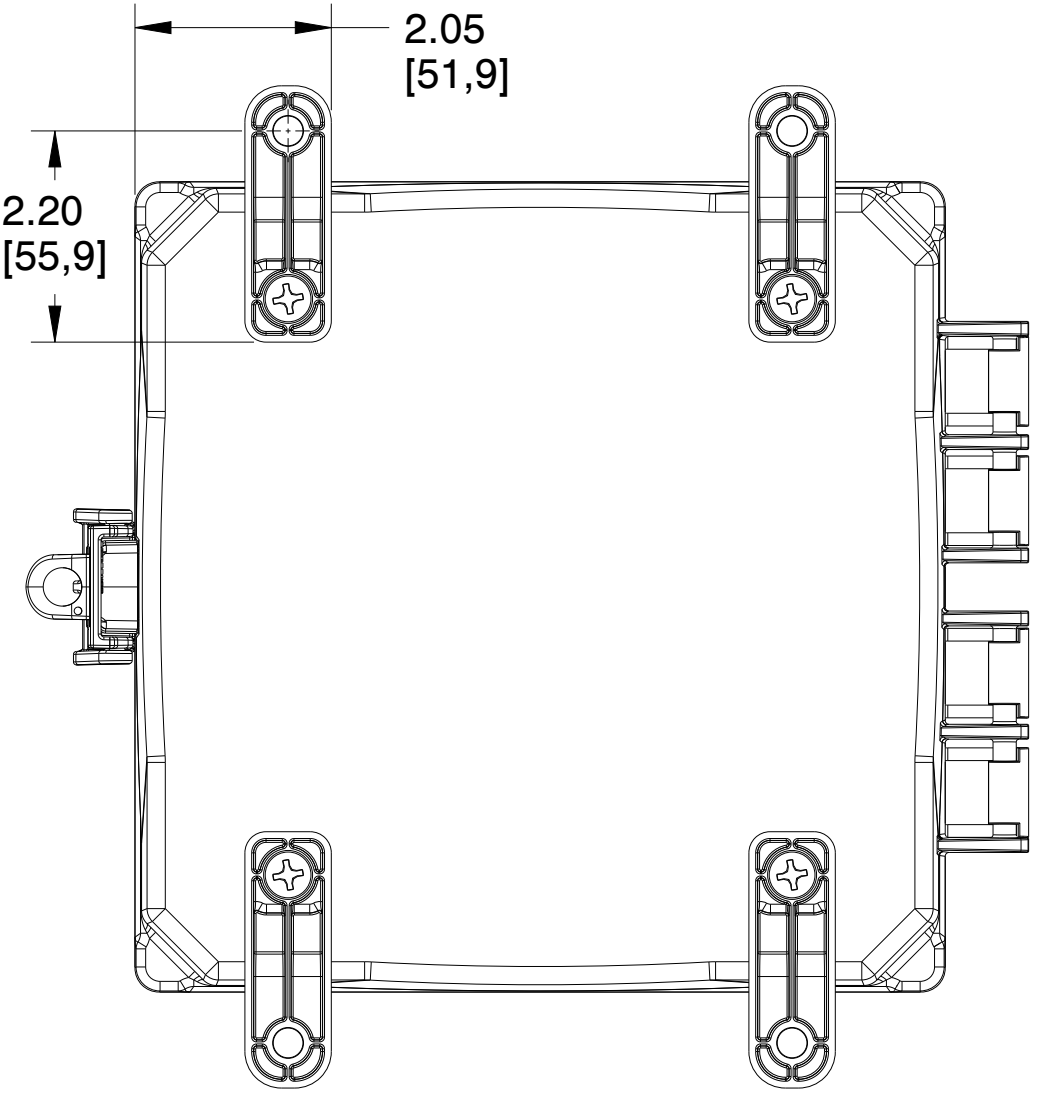
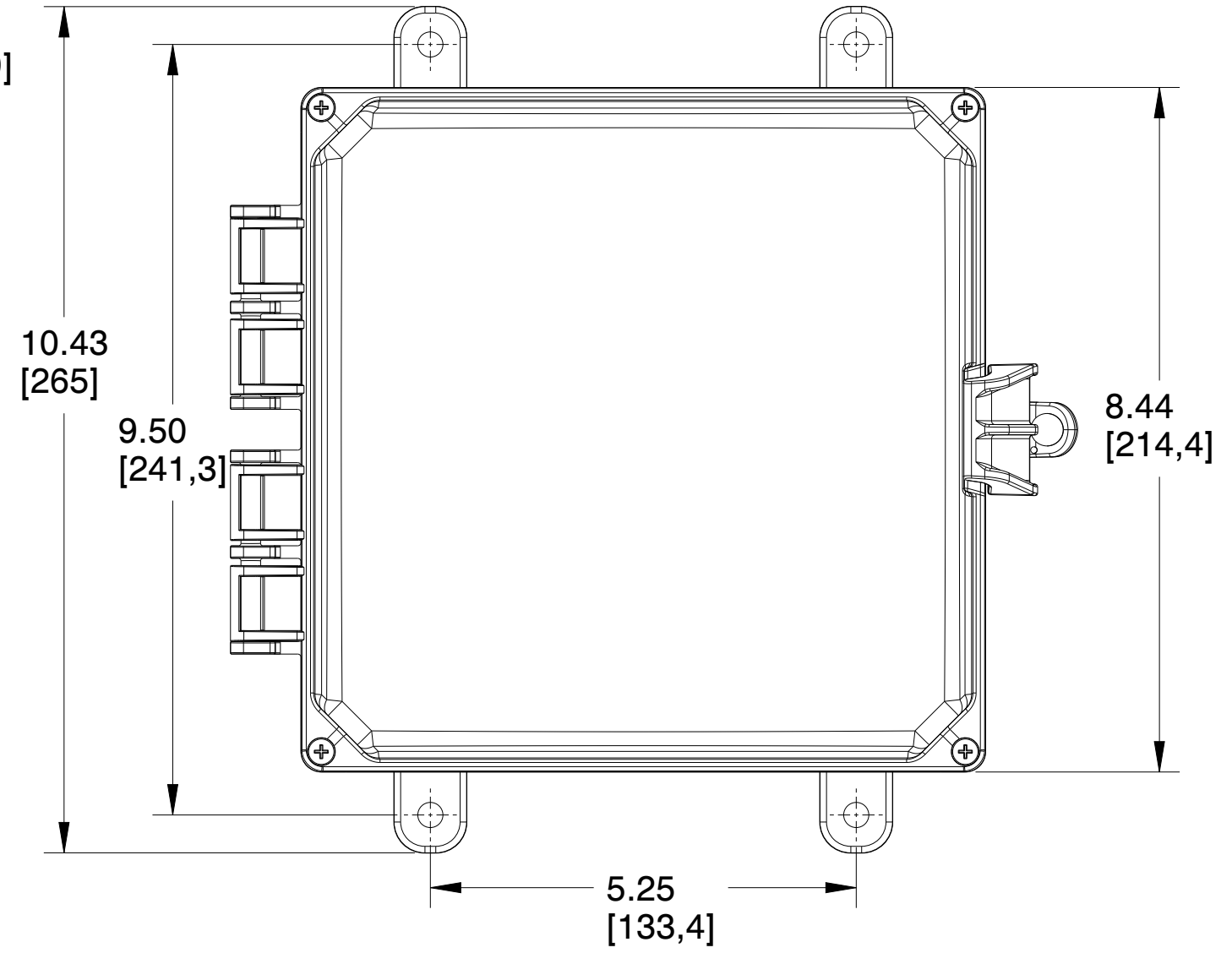
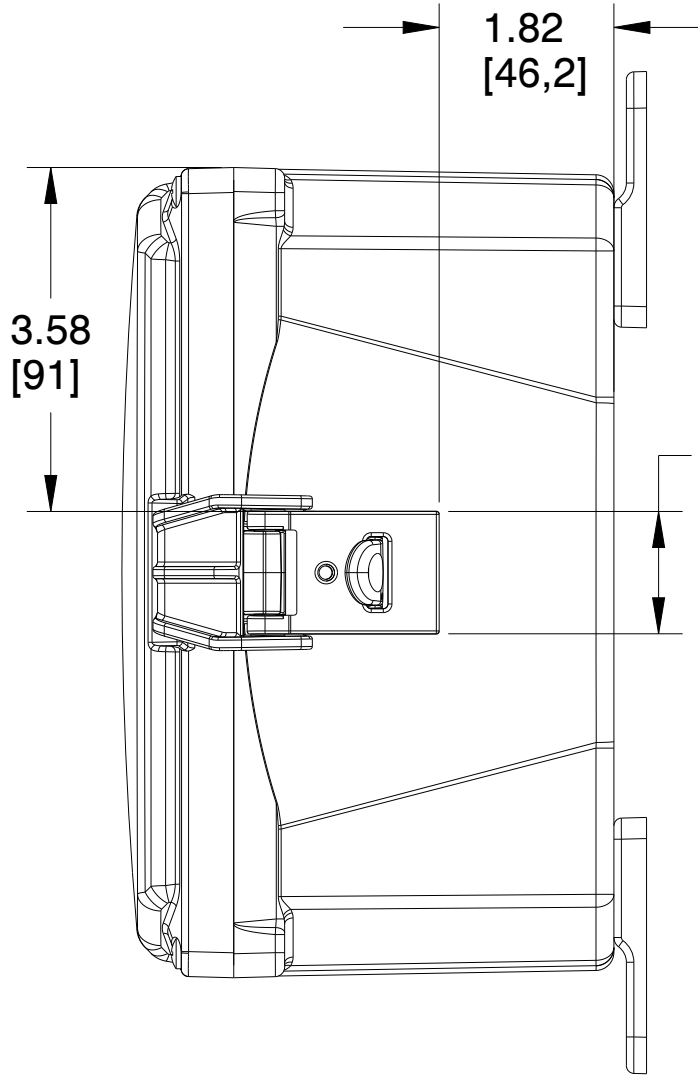
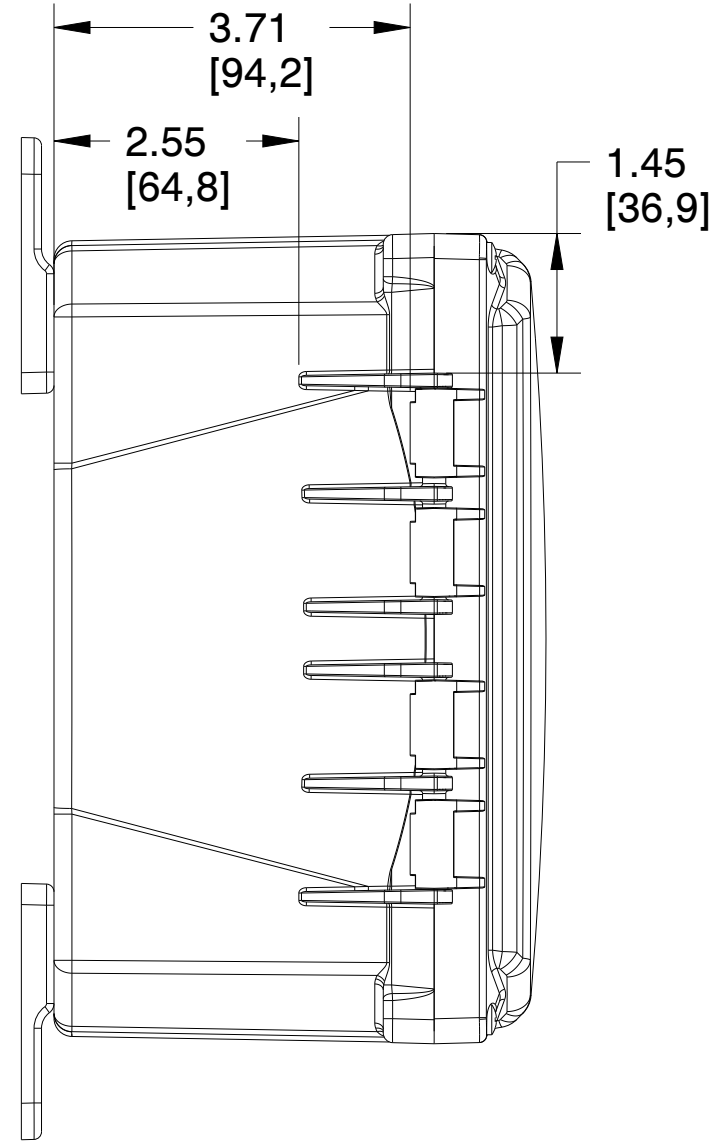
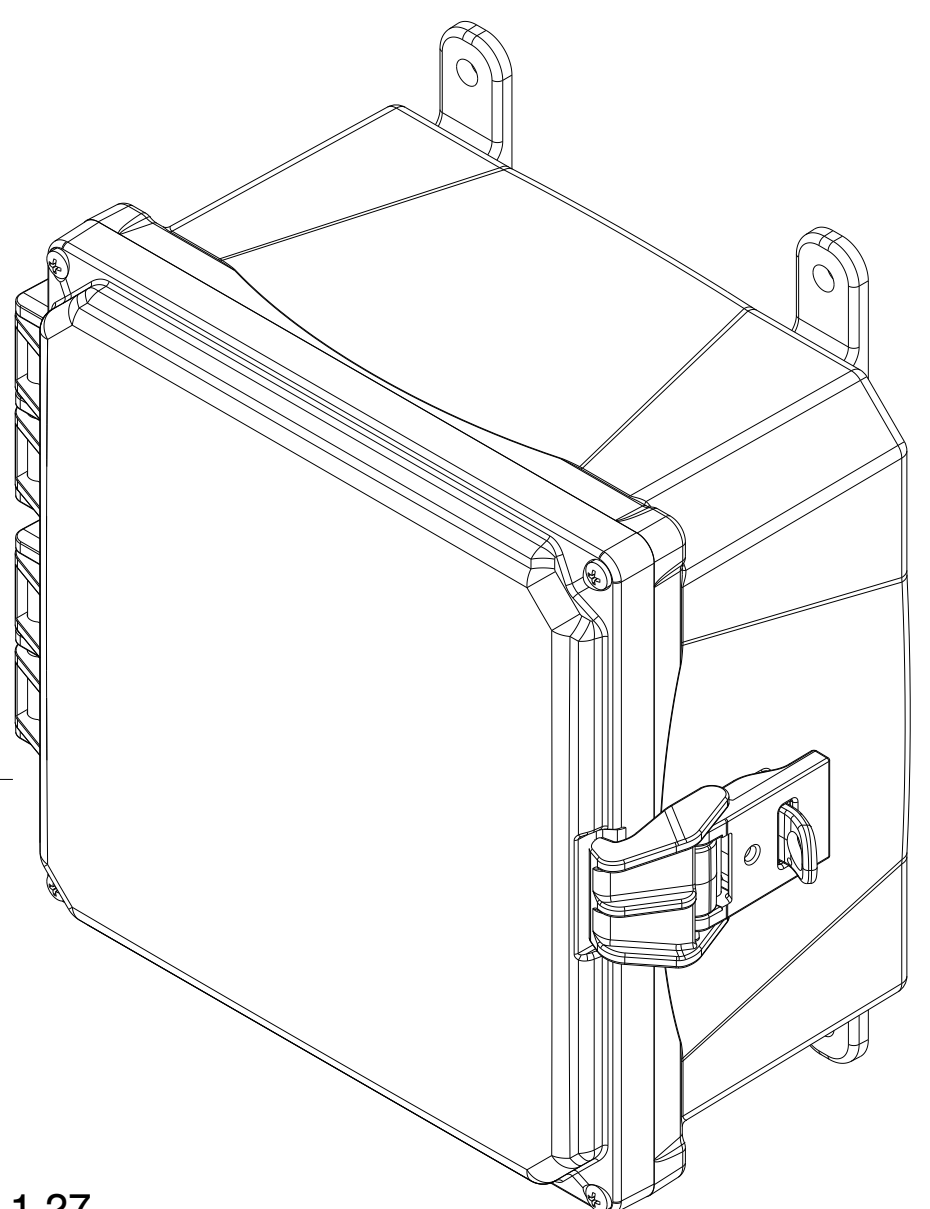
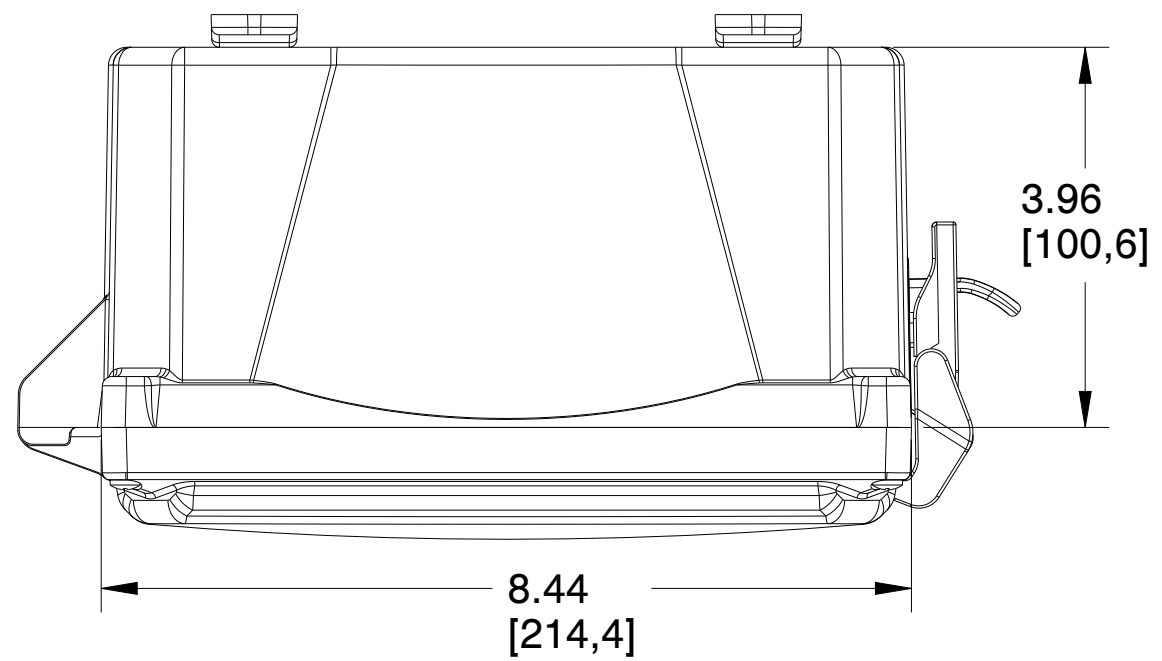

|                        |                |  |  |
|------------------------|----------------|--|--|
|                        |                | MUM INDUSTRIES<br>8989 TYLER BLVD<br>MENTOR, OHIO, U.S.A.<br>(440) 269-8155 FAX (440) 269-8166 |  |
| SCALE                  | SHEET          | DRAWN BY   |  |
| 0.500                  | 1 of 2         | T.PAUL   |  |
| TITLE                  |                |  |  |
| PREM-8X8X4-HNG-GRY-NML |                |  |  |
| DATE                   | DRAWING NUMBER | REV  |  |
| 07.28.2021             | H8084HNL       | A  |  |

UNLESS OTHERWISE SPECIFIED:  
DIMENSIONS ARE IN INCHES (mm)  
AND ARE NOMINAL ONLY

PROPRIETARY AND CONFIDENTIAL:  
THE INFORMATION CONTAINED IN THIS  
DRAWING IS THE SOLE PROPERTY OF  
INTEGRA ENCLOSURES. ANY  
REPRODUCTION IN PART OR AS A  
WHOLE WITHOUT THE WRITTEN  
PERMISSION OF INTEGRA  
ENCLOSURES IS PROHIBITED.

4

3

2

1

D

D

C

C

B

B

A

A

4

3

2

1

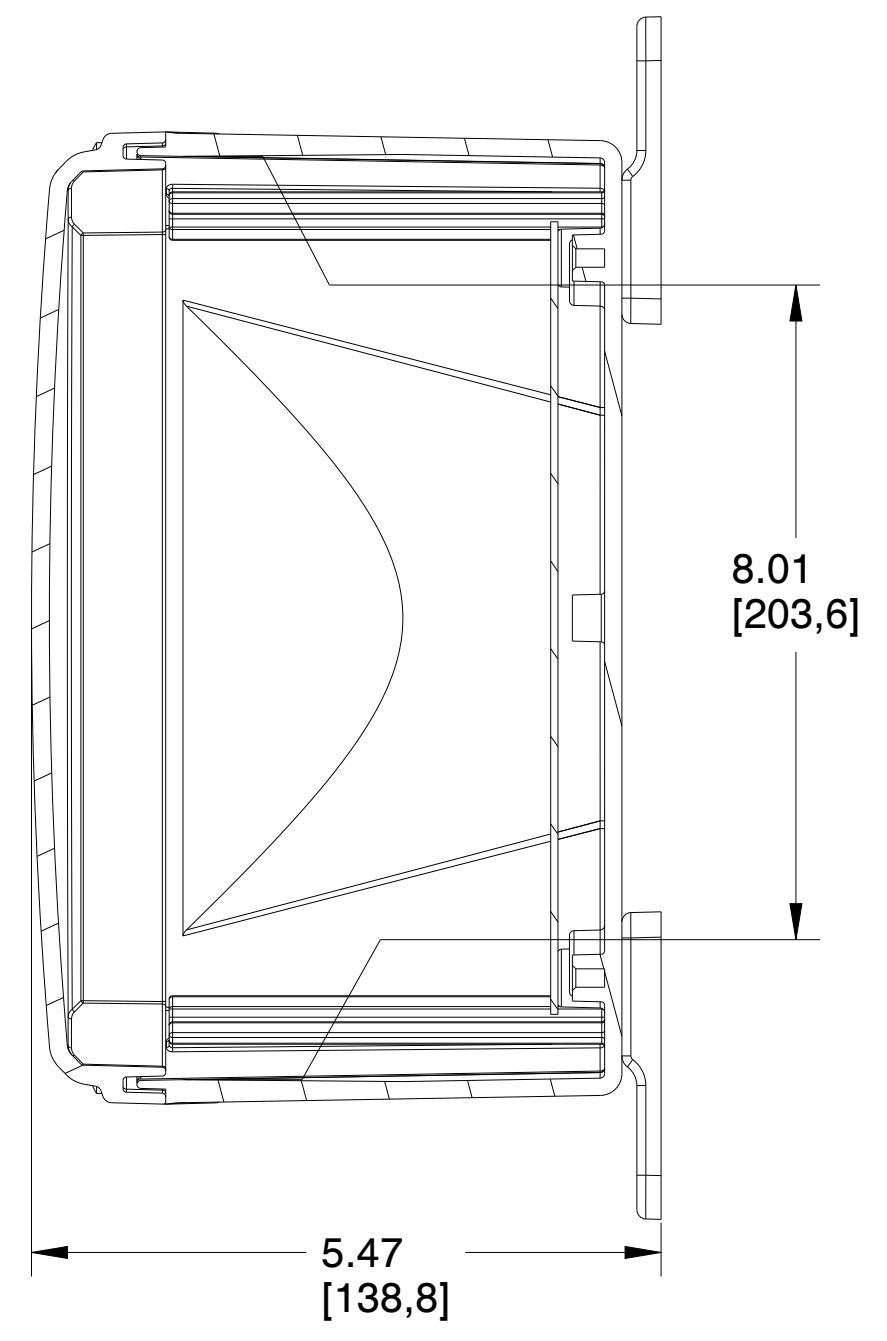
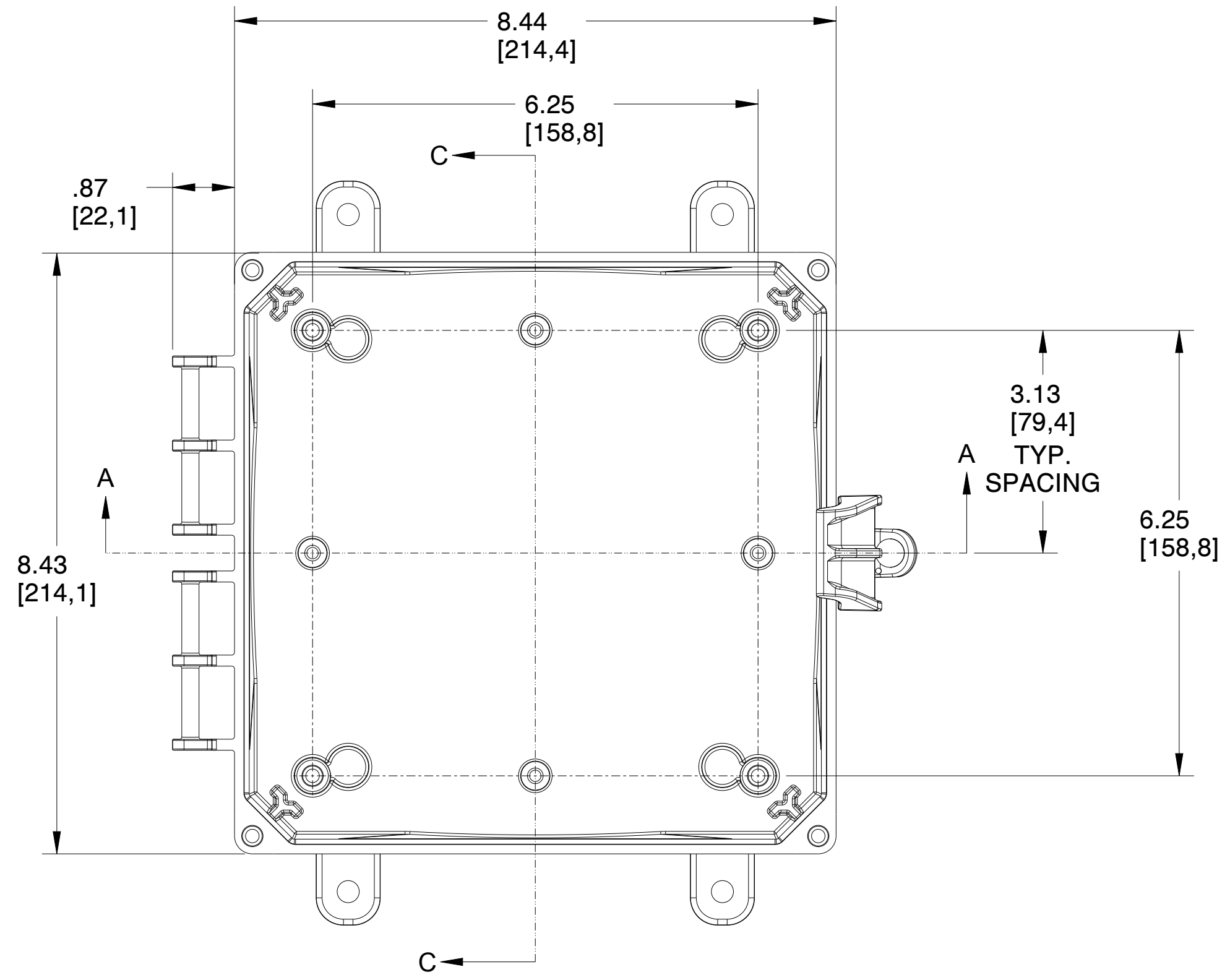

SECTION C-C

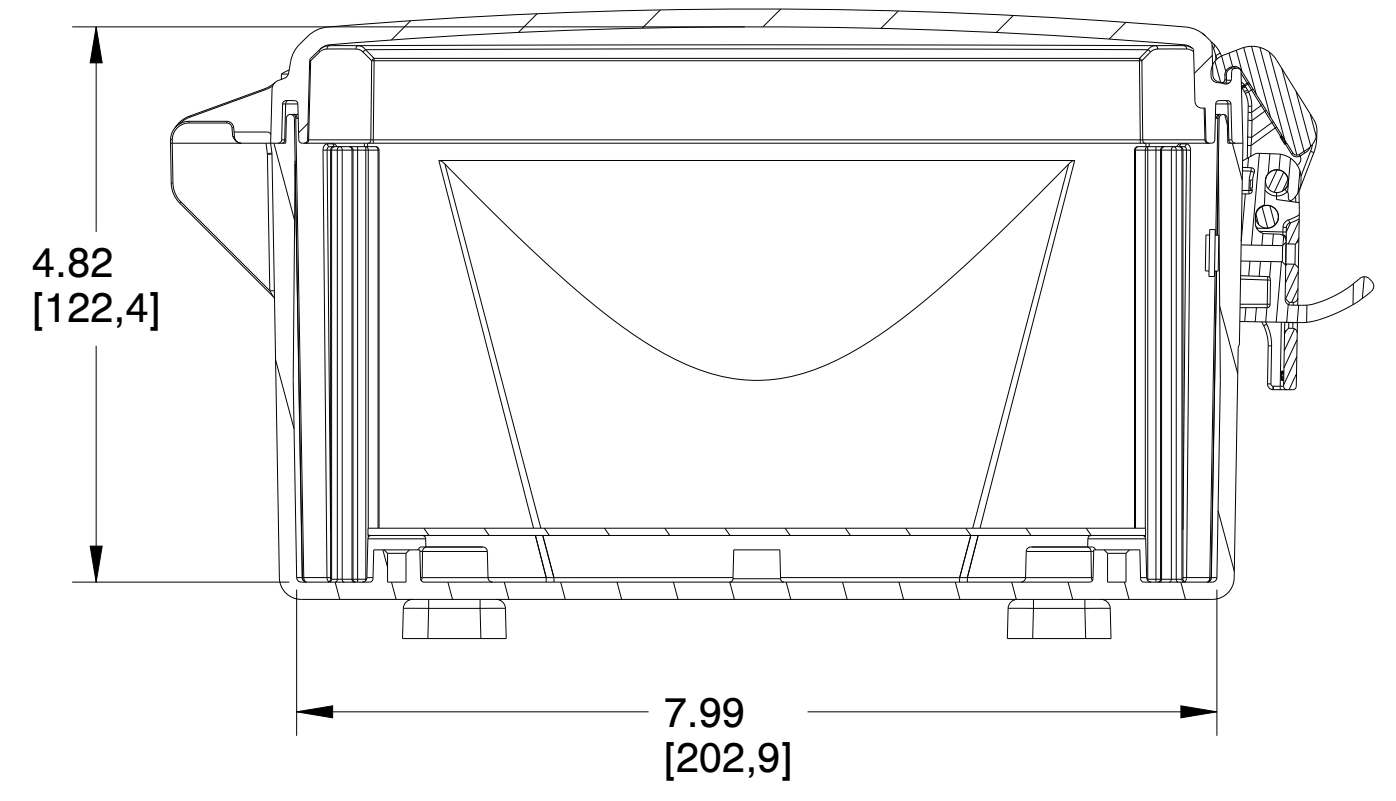

SECTION A-A

|                                 |                            |  |
|---------------------------------|----------------------------|--|
|                                 |                            | MUM INDUSTRIES<br>8989 TYLER BLVD<br>MENTOR, OHIO, U.S.A.<br>(440) 269-8155 FAX (440) 269-8166 |
| SCALE<br>0.600                  | SHEET<br>2 of 2            | DRAWN BY<br>T.PAUL   |
| TITLE<br>PREM-8X8X4-HNG-GRY-NML |                            |  |
| DATE<br>07.28.2021              | DRAWING NUMBER<br>H8084HNL | REV<br>A   |

UNLESS OTHERWISE SPECIFIED:  
DIMENSIONS ARE IN INCHES (mm)  
AND ARE NOMINAL ONLY

PROPRIETARY AND CONFIDENTIAL:  
THE INFORMATION CONTAINED IN THIS  
DRAWING IS THE SOLE PROPERTY OF  
INTEGRA ENCLOSURES. ANY  
REPRODUCTION IN PART OR AS A  
WHOLE WITHOUT THE WRITTEN  
PERMISSION OF INTEGRA  
ENCLOSURES IS PROHIBITED.

4

3

2

1