

OPTIONAL BACK PANEL
 0.100 [2.54] TH'K - ALUMINUM
 0.075 [1.91] TH'K - WHITE STEEL & GALVANNEALED
 0.125 [3.18] TH'K - FIBERGLASS

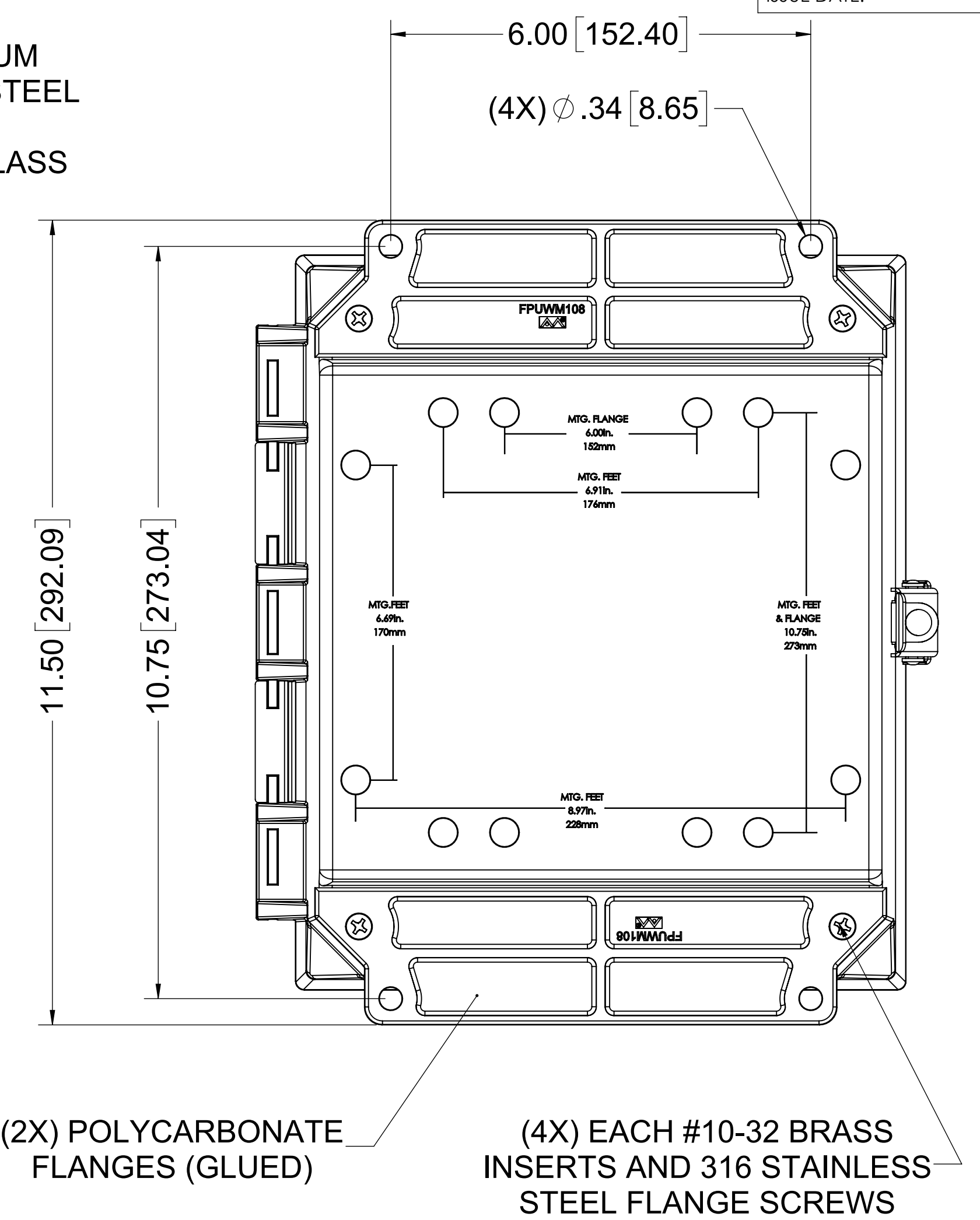

(2X) POLYCARBONATE FLANGES (GLUED)

(4X) EACH #10-32 BRASS INSERTS AND 316 STAINLESS STEEL FLANGE SCREWS

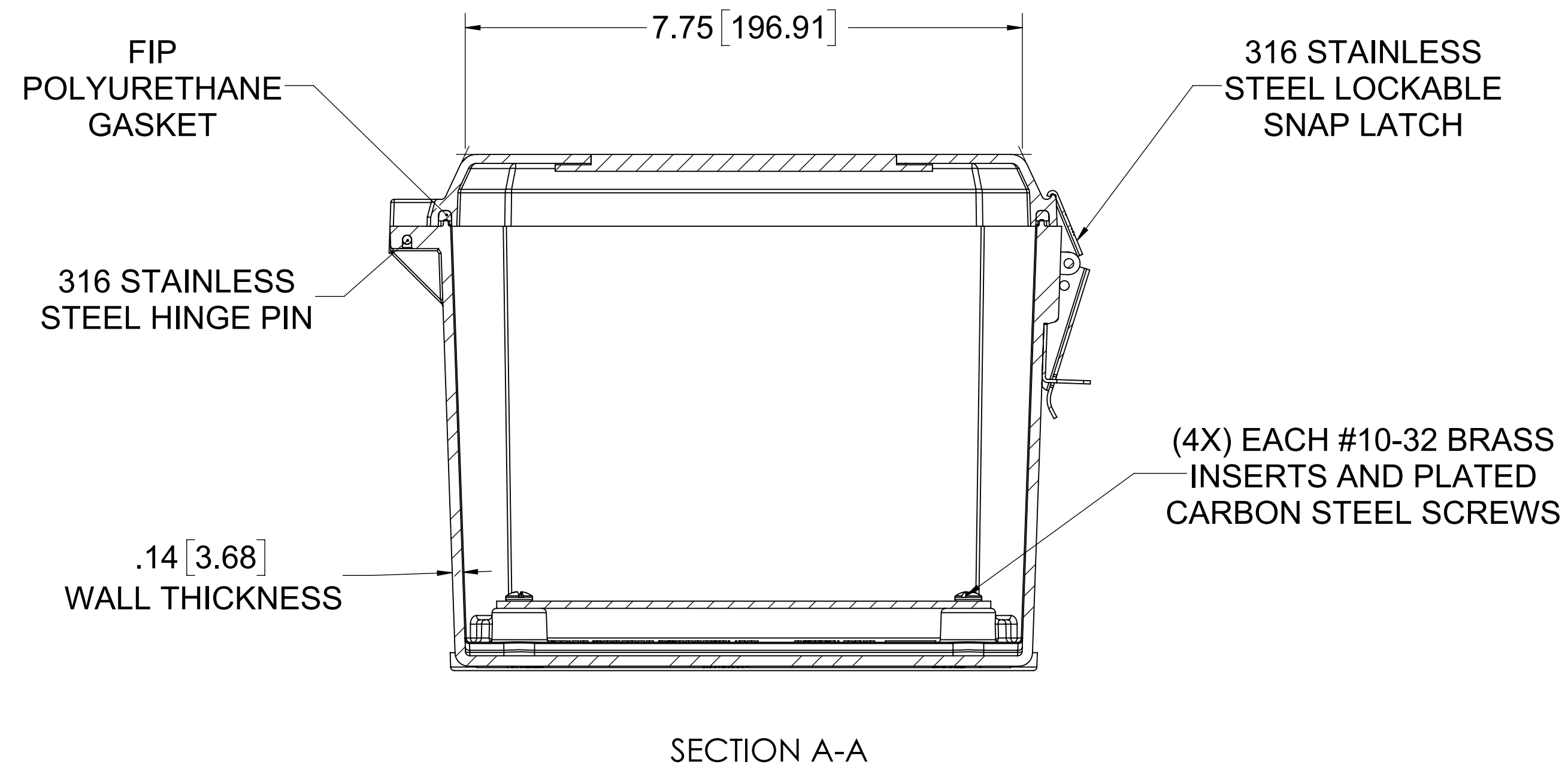

SECTION A-A

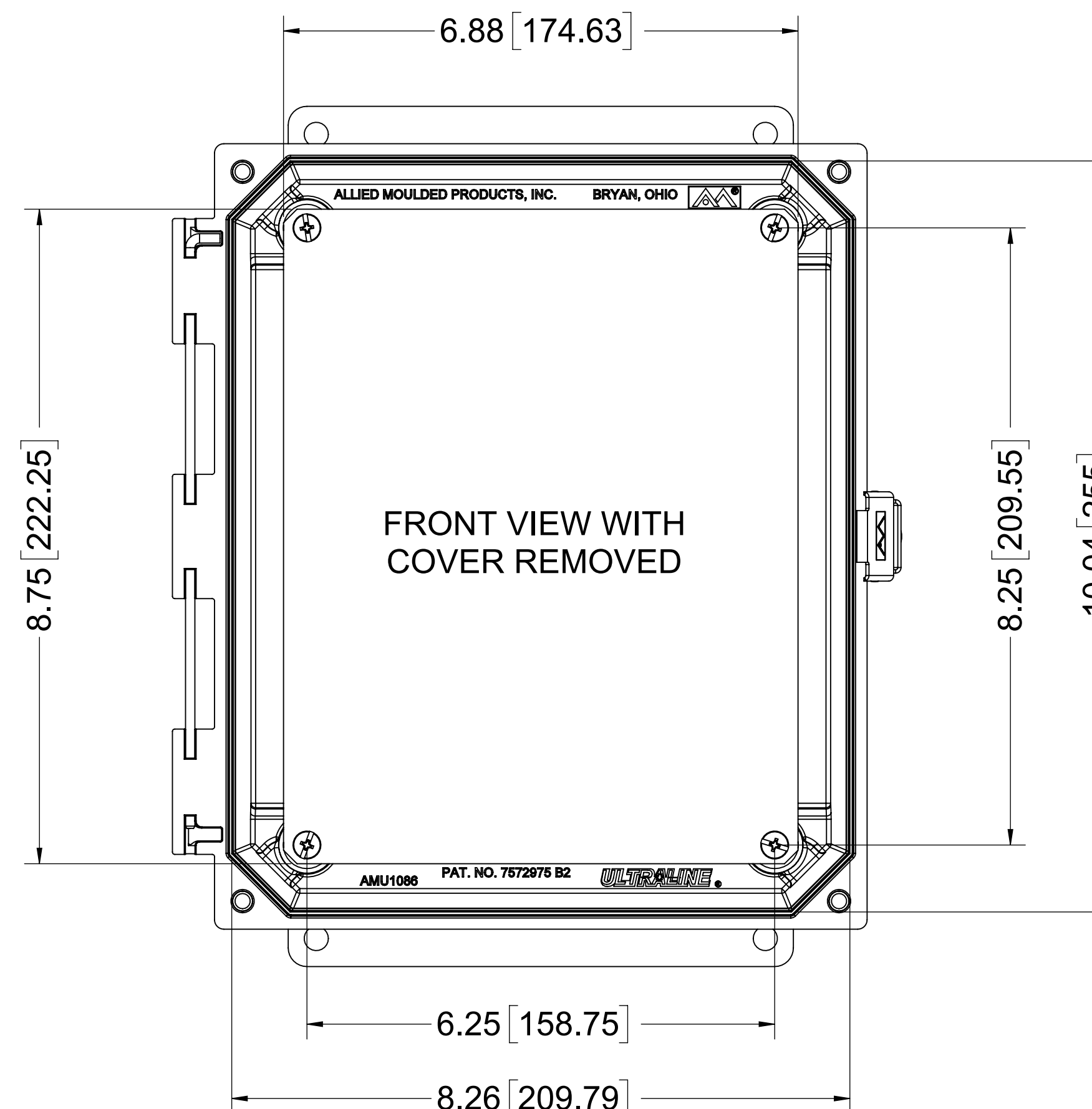

FRONT VIEW WITH COVER REMOVED

NOTE:
 1. DATA SUBJECT TO CHANGE WITHOUT NOTICE

MATERIAL:
 BOX - COMPRESSION MOLDED FIBERGLASS REINFORCED POLYESTER
 COVER - COMPRESSION MOLDED FIBERGLASS REINFORCED POLYESTER
 CLEAR COVER AND WINDOW - INJECTED POLYCARBONATE

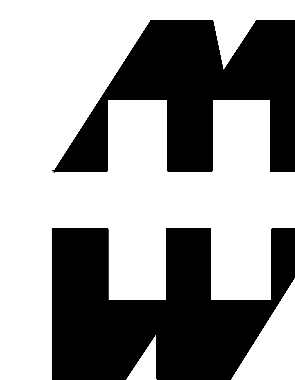

PART No. PJU1086LWF.WEB

for more information visit
www.hammfg.com
 Data subject to change without notice
 Drawing Not to Scale