

OPTIONAL BACK PANEL SHOWN  
 0.100 [2.54mm] TH'K- ALUMINUM  
 0.075 [1.91mm] TH'K- WHITE STEEL  
 0.188 [4.78mm] TH'K- PVC

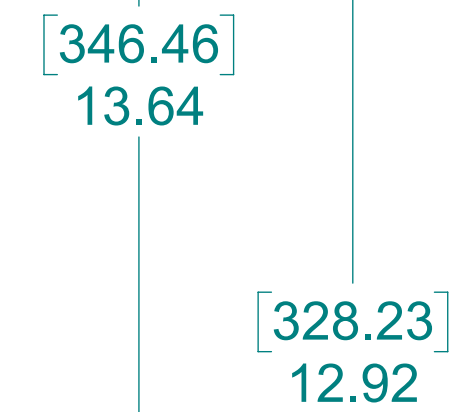

(4X) POLYCARBONATE FEET

(4X) EACH #10-32 BRASS INSERTS AND 316 STAINLESS STEEL FEET SCREWS

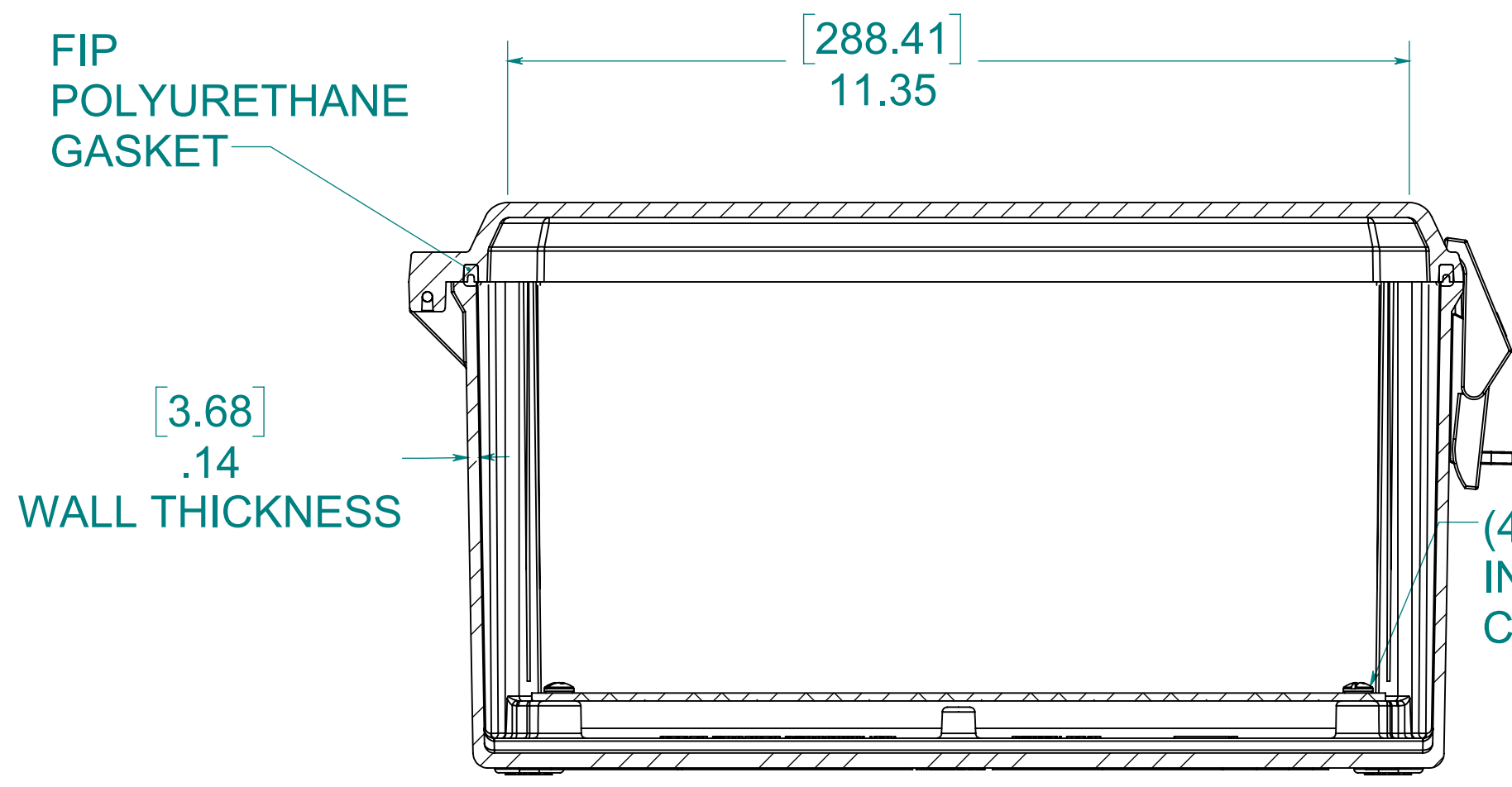

SECTION B-B

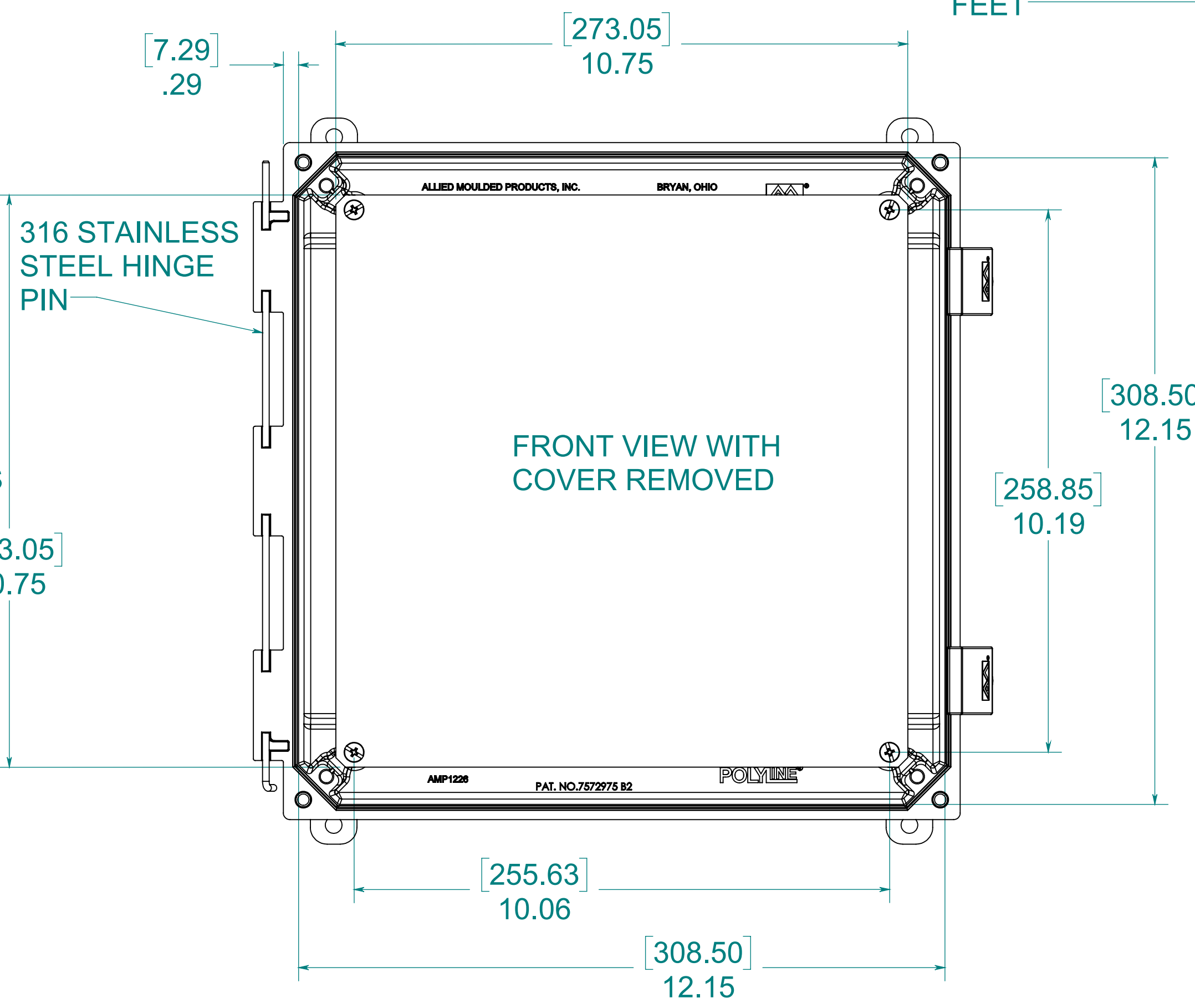

FRONT VIEW WITH COVER REMOVED

316 STAINLESS STEEL HINGE PIN

(4X) EACH #10-32 BRASS INSERTS AND PLATED CARBON STEEL SCREWS

MATERIAL:  
 BOX- INJECTED POLYCARBONATE  
 STANDARD COVER- INJECTED POLYCARBONATE  
 CLEAR COVER- INJECTED POLYCARBONATE

NOTE:  
 1. DATA SUBJECT TO CHANGE WITHOUT NOTICE

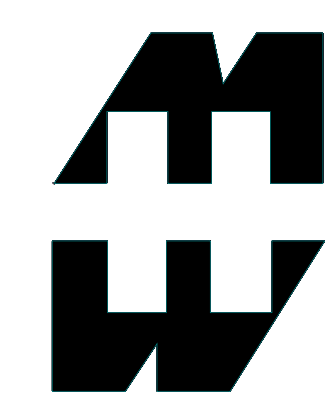

PART No. PCJ12126NL

for more information visit [www.hammfg.com](http://www.hammfg.com)  
 Data subject to change without notice  
 Drawing Not to Scale