

PART NAME	SERVER RACK PROFESSIONAL SERIES	PART No.	SRP-8131 to SRP-8137	SRP-8141 to SRP-8147	REV. DATE	3-9-12
-----------	---------------------------------	----------	----------------------	----------------------	-----------	--------

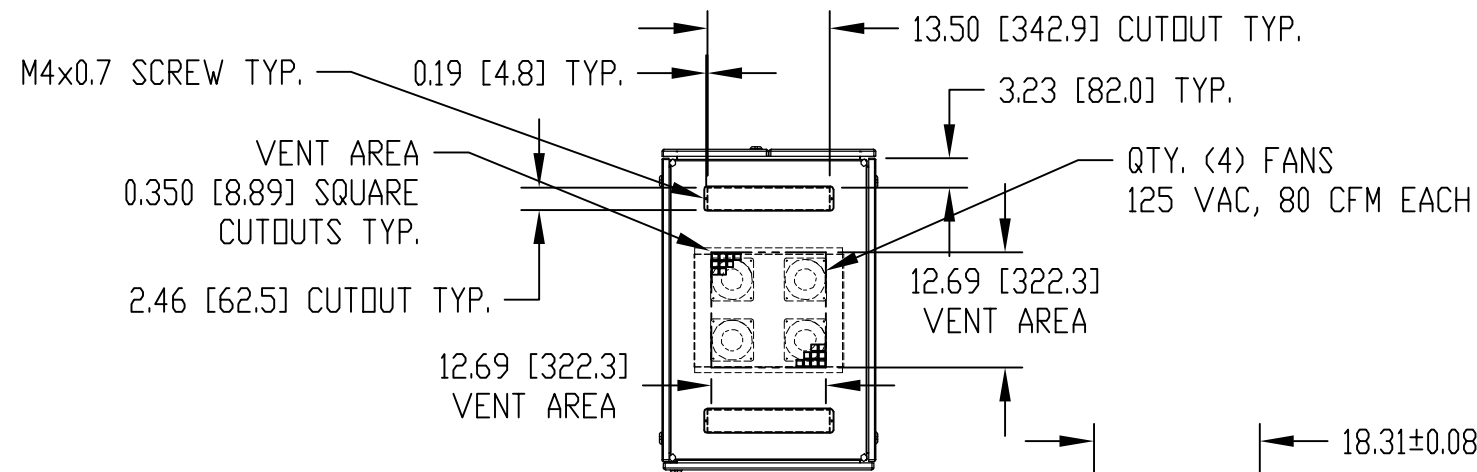

MATERIAL:
 PANEL MOUNTING RAILS - 14 GA. [2.0mm] STEEL
 SHELF - 18 GA. [1.2mm] STEEL
 ALL OTHER PARTS - 18 GA. [1.2mm] STEEL

FINISH:
 BLACK TEXTURED POWDER COATING

PANEL MOUNTING RAILS HAVE 0.350 [8.89] SQUARE HOLES ON E.I.A. UNIVERSAL HOLE SPACING

SUPPLIED HARDWARE KIT TO INCLUDE:
 QTY. "Y" M6 CAGE NUT
 QTY. "X" M6 PAN HEAD SCREW
 QTY. "W" NYLON FLAT WASHER
 QTY. (8) KEYS

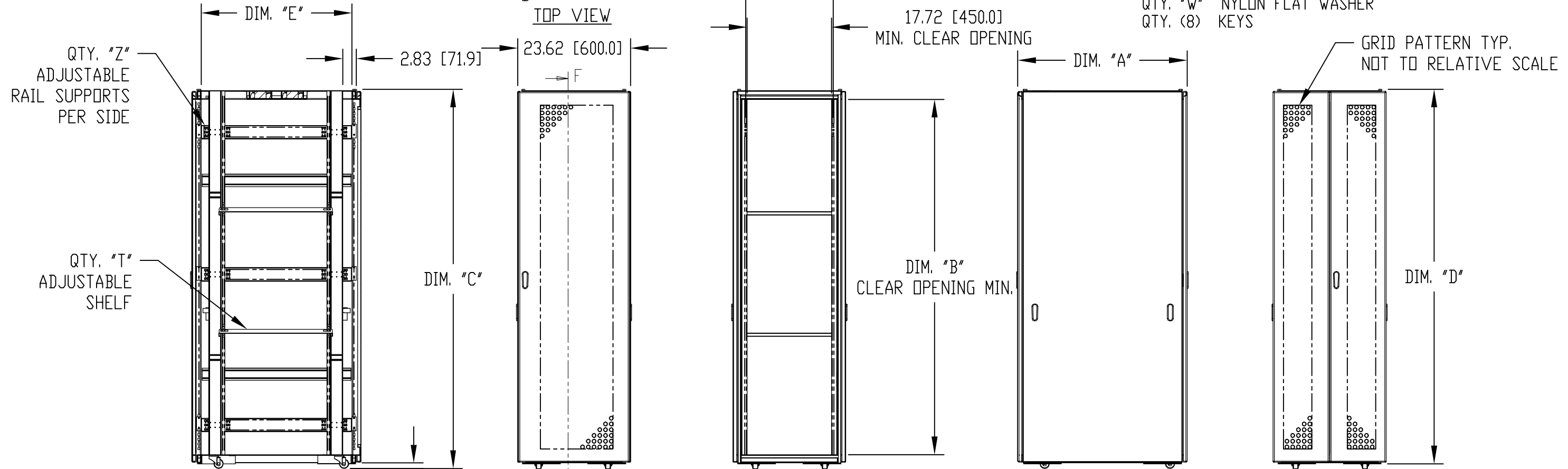

TOLERANCES: ALL DIMENSIONS ±0.08 [2.0]

PART NO.	UNIT	"A"	"B" CLEAR MIN.	"C"	"D"	"E"	"Z"	"Y"	"X"	"W"	"T"
SRP-8131	27U	35.43 [900.0]	47.32 [1202.0]	52.32 [1329.0]	51.14 [1299]	31.56 [801.6]	2	25	25	25	1
SRP-8134	42U	35.43 [900.0]	73.90 [1877.0]	78.70 [1999.0]	77.52 [1969]	31.56 [801.6]	3	40	40	40	2
SRP-8137	45U	35.43 [900.0]	79.15 [2010.4]	83.95 [2132.3]	82.77 [2102.4]	31.56 [801.6]	3	40	40	40	2
SRP-8141	27U	43.31 [1100.0]	47.32 [1202.0]	52.32 [1329.0]	51.14 [1299]	39.43 [1001.6]	2	25	25	25	1
SRP-8144	42U	43.31 [1100.0]	73.90 [1877.0]	78.70 [1999.0]	77.52 [1969]	39.43 [1001.6]	3	40	40	40	2
SRP-8147	45U	43.31 [1100.0]	79.15 [2010.4]	83.95 [2132.3]	82.77 [2102.4]	39.43 [1001.6]	3	40	40	40	2

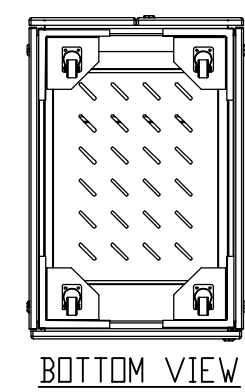

BOTTOM VIEW