

MATERIAL:
 PANEL MOUNTING RAILS - 14 GA. (0.08" [2.0] THK.) STEEL
 ALL OTHER PARTS - 18 GA. (0.05" [1.2] THK.) STEEL

FINISH:
 BLACK TEXTURED POWDER COATING

PANEL MOUNTING RAILS HAVE 0.35" [8.9] SQUARE HOLES
 ON E.I.A. UNIVERSAL HOLE SPACING

SUPPLIED HARDWARE KIT TO INCLUDE:
 QTY. (25) M6 CAGE NUT
 QTY. (25) M6 PAN HEAD SCREW
 QTY. (25) NYLON FLAT WASHER
 QTY. (4) M10 x 2.25" [57.2] LG. STEM LEVELER W/HEX NUT
 QTY. (8) KEYS

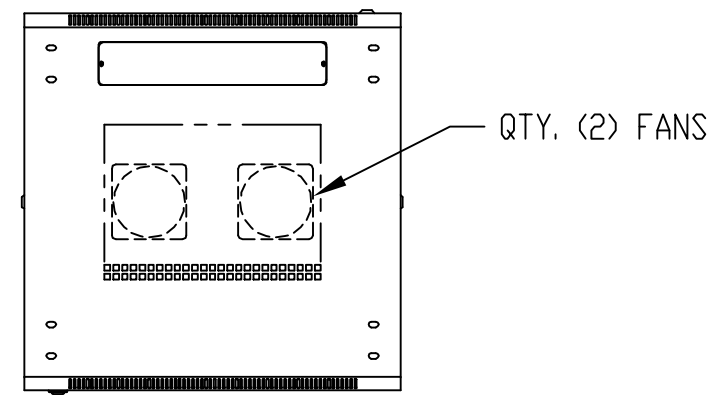

TOP VIEW

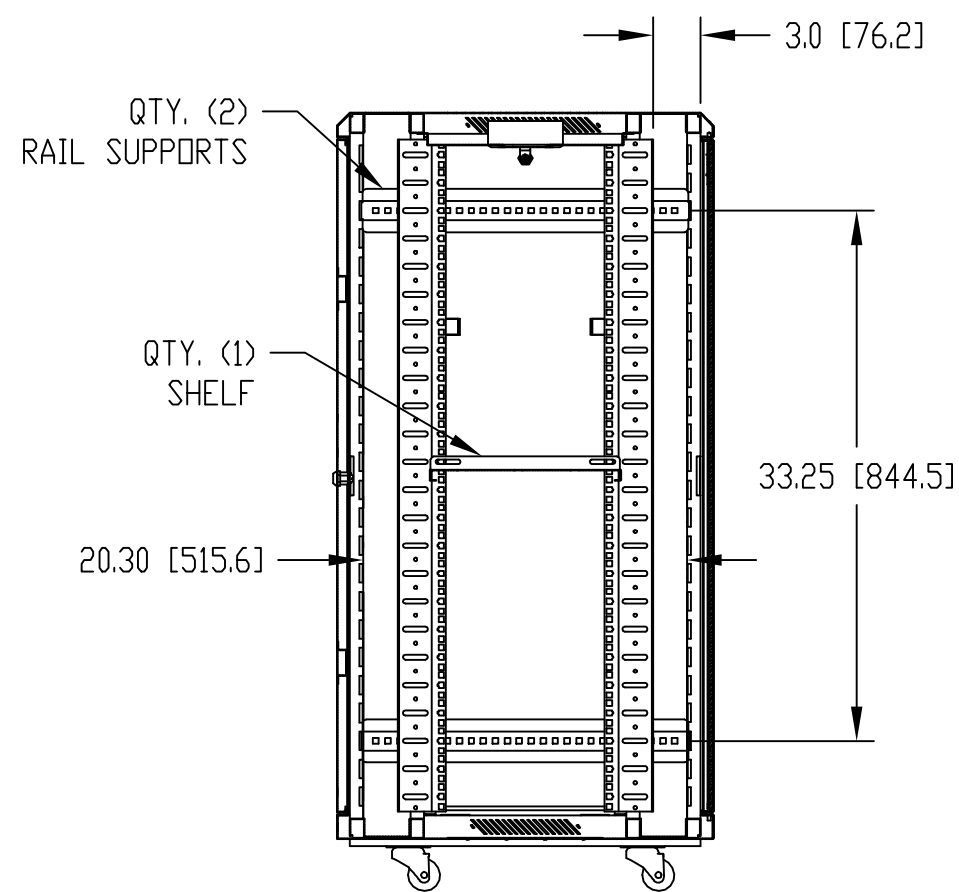

SECTION "A-A"

2.85 [71.6] REF. CASTER HT.

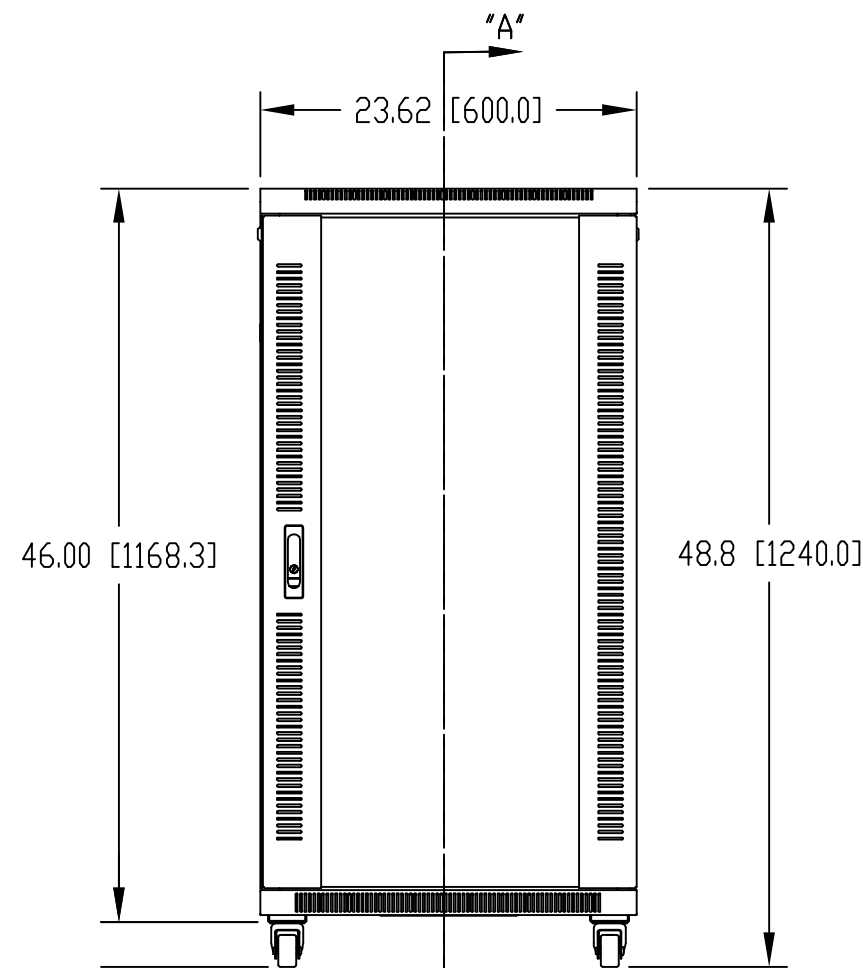

FRONT VIEW

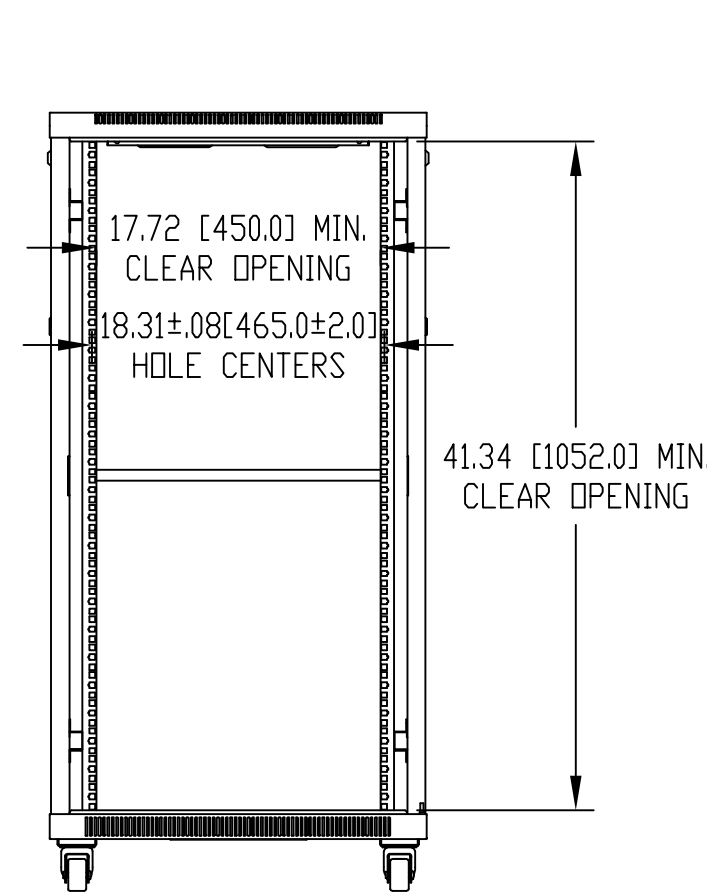

FRONT VIEW (DOOR REMOVED)

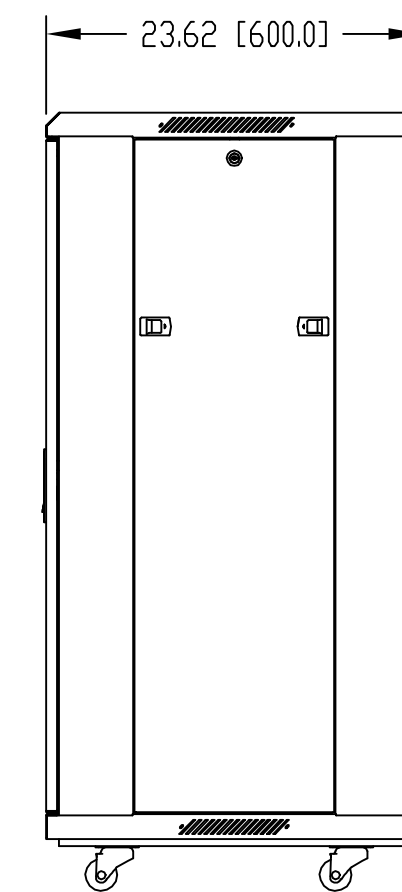

RIGHT SIDE VIEW

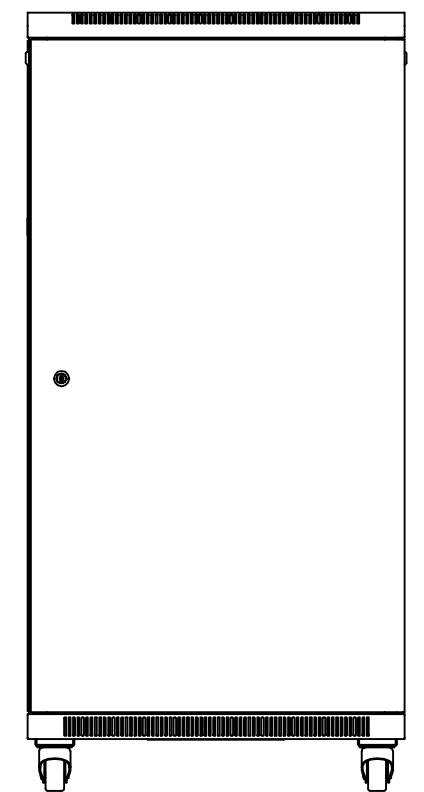

BACK VIEW

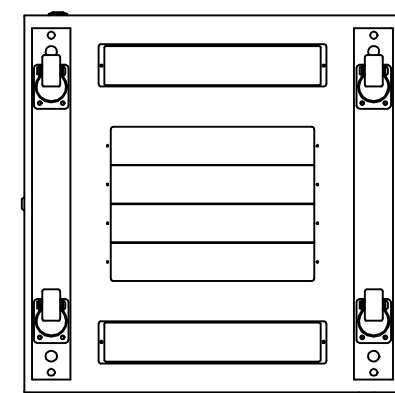

BOTTOM VIEW

TOLERANCE ALL DIMENSIONS: ±0.08" [2.0]

		ITEM	REQ'D.	PART NO.	DESCRIPTION	
QTY.	USED ON	TOLERANCES:			NAME: 24U BUDRACK PROFESSIONAL SERIES DWG. NO. BRP-12202	
		±.005 BETWEEN HOLE CENTERS				MAT: AS NOTED
		±.015 FROM SHEARED EDGE				FINISH: AS NOTED
		±.032 FROM A BENT SURFACE				DR. DAB 6-20-08
		UNLESS OTHERWISE SPECIFIED			BUD INDUSTRIES, INC. WILLOUGHBY, OHIO	
		CH.				
		APP.				