



PART NAME

NEMA DIE CAST ALUMINUM ENCLOSURE

PART No.

AN-1322-A & AN-1322-AB

REVISION DATE

9-30-15

UL LISTED FOR U.S. AND CANADA - FILE #E194432

TYPE RATING 4, 4X, 6, 6P, 12 AND 13, COMPARE TO IP-68

80°C. MAXIMUM OPERATING TEMPERATURE

UPDATE REPLACES PART NO. AN-1322 (NATURAL) & AN-1322-G (DISCONTINUED GRAY)

DRAWING FOR REFERENCE
WE RESERVE THE RIGHT TO MAKE CHANGES TO OUR STANDARD PRODUCTS. PLEASE CONSULT WITH BUD INDUSTRIES PRIOR TO USING THIS DRAWING FOR DESIGN PURPOSE.

BODY COVER NOT SHOWN

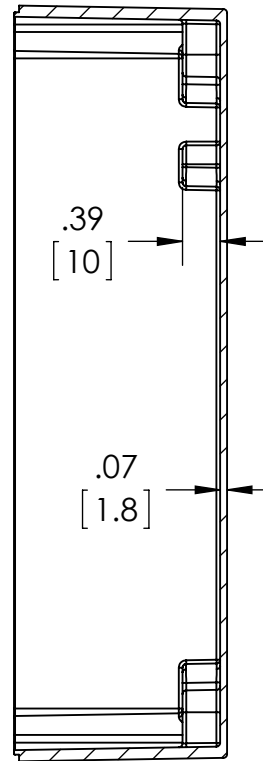
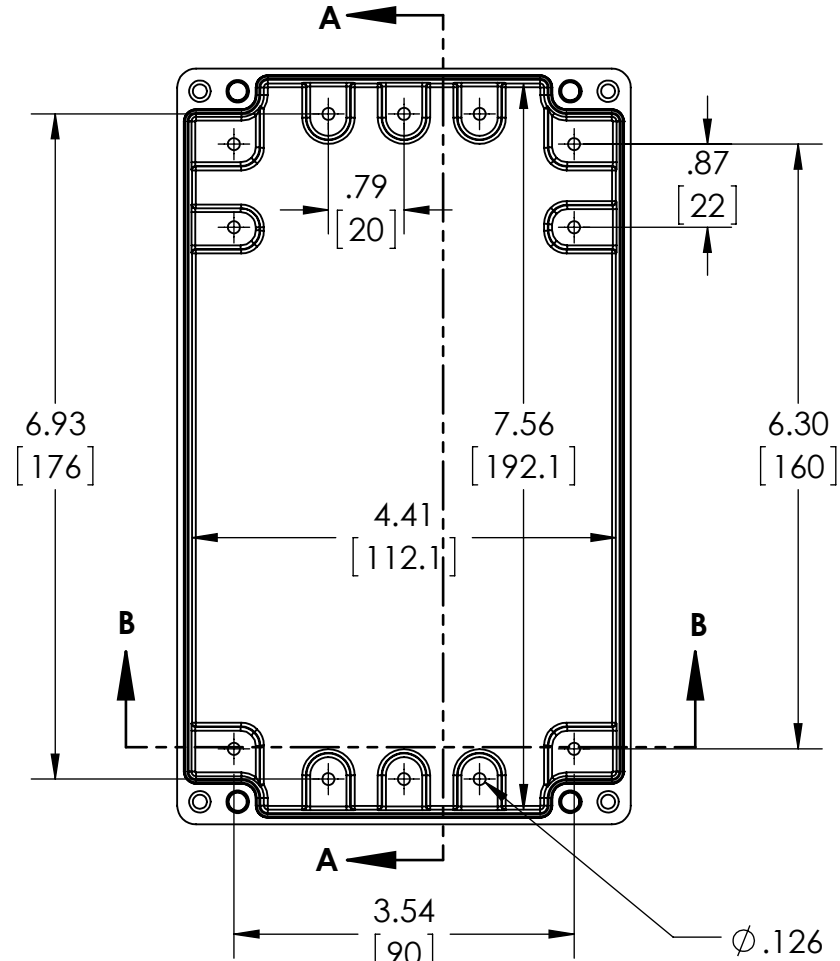

SECTION A-A

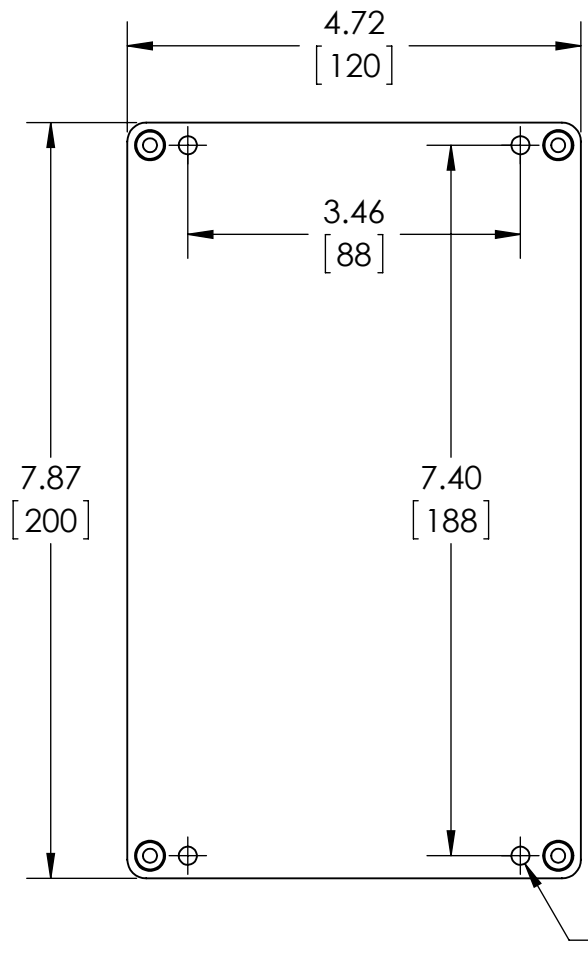

GASKET (NOT INSTALLED)
MOLDED SILICONE GRAY

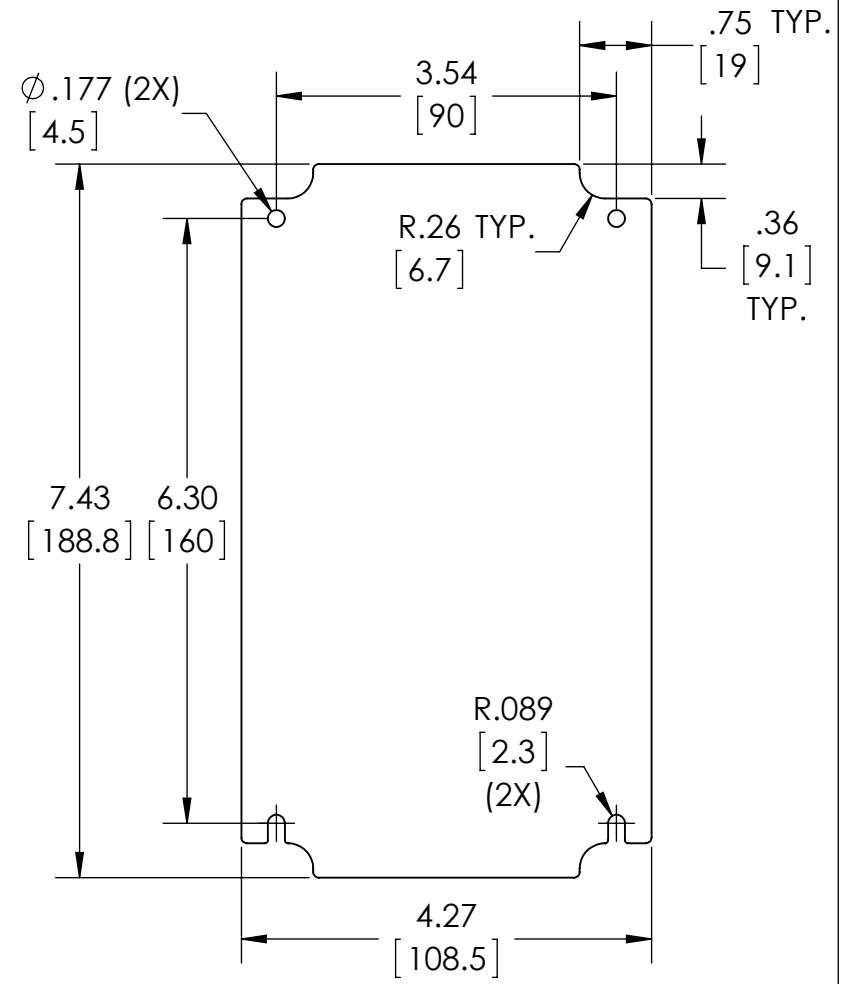
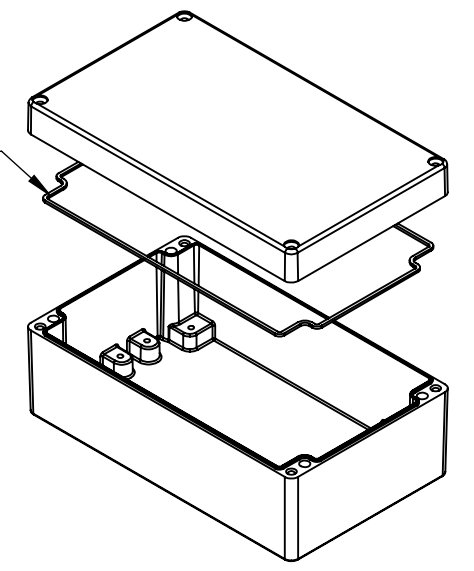

OPTIONAL INTERNAL PANEL AND
SUGGESTED PC BOARD LAYOUT

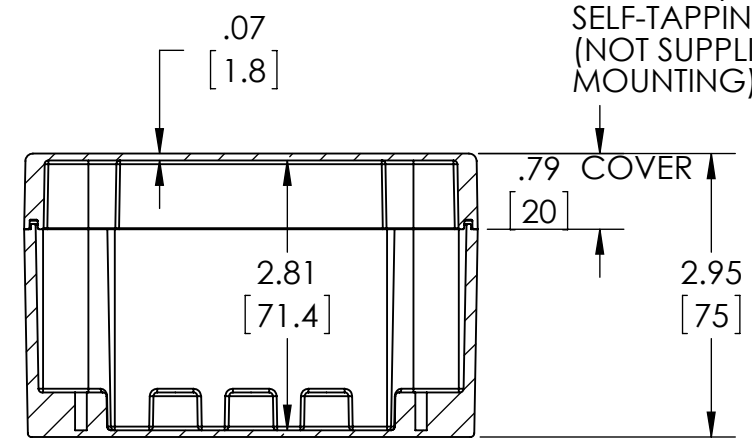

SECTION B-B

Ø.126 x .07 DEEP (12X)
[3.2] [1.8]
ACCEPTS M3.5 x 6mm LG.
OR #6 x 1/4" LG.
SELF-TAPPING SCREW
(NOT SUPPLIED - FOR PCB
MOUNTING)

MATERIAL: BODY & COVER - ALUMINUM ALLOY #ADC-12

FINISH: NATURAL (SUFFIX -A)
SMOOTH BLACK POWDERCOAT (SUFFIX -AB)

FOUR (4) M4x0.7 x 32mm (1.26") LG. 90° CSK. HEAD
STAINLESS STEEL CAPTIVE SCREWS SUPPLIED FOR
ASSEMBLY OF COVER TO BODY. APPLY AT 12 IN./LB. OF
TORQUE.

OUTSIDE AND INSIDE DRAFT ANGLE: 1°
DIMENSIONS IN INCH[MM]

OPTIONAL ACCESSORIES:
PCB MOUNTING KIT #57-58
INTERNAL PANEL #ANX-91322
WALL MOUNT BRACKETS #ANX-1390
REPLACEMENT GASKET #1322GSKTSC