

PSD-15 Series

FEATURES

- High Efficiency
- 100% Full Load Burn-In
- Low Ripple & Noise
- Adjustable DC Voltage Output
- Class II Isolation Level
- UL62368-1 and CAN / CSA C22.2
- Protections: Overload / Over Voltage / Short Circuit
- Three-year Warranty

- **Low Profile**
- **Small size**
- **Universal input**
- **Three-year Warranty**



Input: 90-240VAC 50/60Hz
Output Voltage: 5V-48V DC
Rated Power: 15W max.



CATALOG NUMBER

PSD-1505

PSD-1512

PSD-1515

PSD-1524

PSD-1548

INPUT

Input Voltage	90-264VAC				
Input Frequency	47-63Hz				
Inrush Current	25 Amps max. at 115VAC/60Hz, Full Load & 45Amps max. at 240VAC/50Hz, Full Load				
AC Current	0.5A/115VAC 0.25A/230VAC				
Leakage Current (MAX)	<0.25mA/240VAC				
Efficiency	79%	85%	85%	86%	87%

OUTPUT

DC Voltage	5V	12V	15V	24V	48V
Rated Current	2A	1.25A	1A	0.63A	0.32A
Rated Power	10W	15W	15W	15W	15W
Ripple and Noise	80mVp-p	120mVp-p	120mVp-p	150mVp-p	240mVp-p
Line Regulation	±1%				
Load Regulation	±1%				
Setup, Rise, Hold Up Time	2S/ 80mS/ 15mS (115V/60HZ MAX ROAD); 1S/ 80mS/ 30mS (230V/50HZ MAX ROAD)				

ENVIRONMENTAL

Operating Temperature	-20°C to 50°C, Full Load, Normal Operation
Storage Temperature	-40°C to 80°C
Storage Humidity	10 ~ 95% RH
Working Humidity	20% ~ 90% RH Non-Condensing

PROTECTIONS

Overload Protection	>130%-200% Rated Output Power Protection type: Hiccup Mode- recovers automatically after fault condition is removed
Over Voltage Protection	110~145% Protection Type: Clamp by Zener diode
Short Circuit Protection	Protection to Zero Voltage
Over Current Protection	110%-180%

SAFETY & EMC

Safety Regulations	UL60950-1, UL508, BSMI CNS14336-1, TUV EN61558-2-16 IEC60950-1, EAC TPTC 004, TUV EN60950-1 UL62368-1 and CAN / CSA C22.2 No.62368-1-14
Withstand Voltage	I/P-O/P: 3KVAC
Isolation Resistance	I/P-O/P: 100M Ohms / 500VDC / 25 / 70% RH
EMC Emission	EN55032(CISPR32), CNS13438 Class B, EN61000-3-2 Class A, EN61000-3-3, EN61000-4-2,3,4,5,6,8,11, EN55024, EN55035, EN61000-6-2, EN61204-3

OTHER

MTBF	200,000 Hours Minimum at Full Load at 25°C Ambient
Size	90 x 18 x 58mm
Weight	78g / pcs
Packaging	100PCS/CTN

Mechanical Specification

Pin #	Assignment	Pin #	Assignment
1	+V	3	AC / N
2	-V	4	AC / L

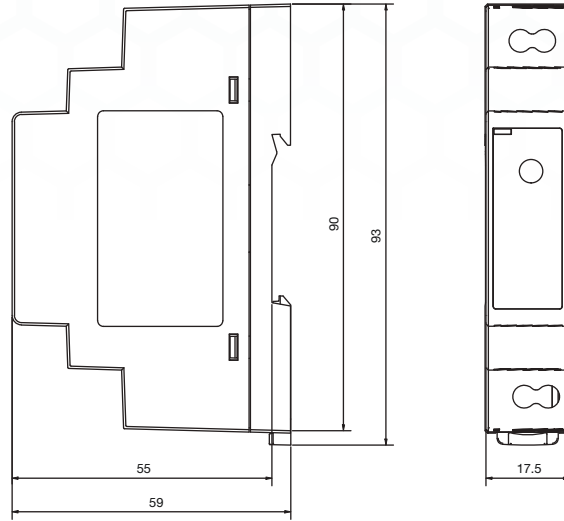

Block Diagram

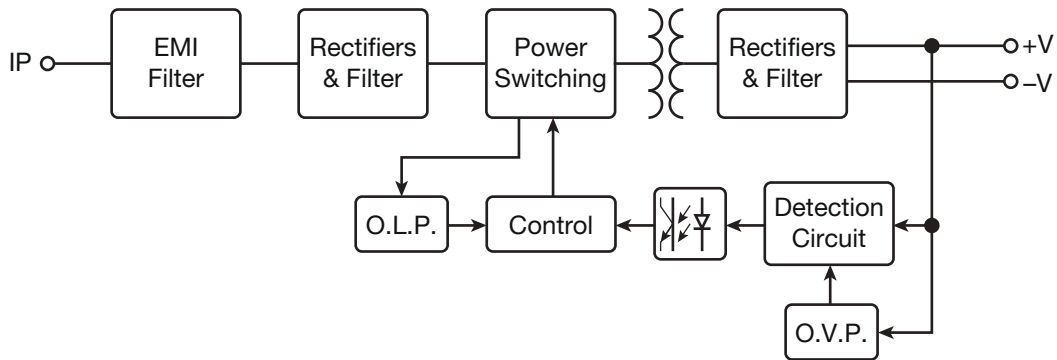

Deduction Curve and Temperature:

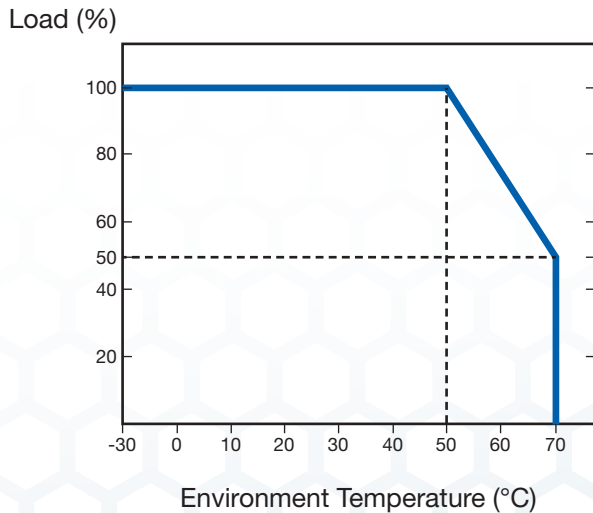

Minus Output and Input Voltage Curves:

