

(4X) SNAP-IN POLYCARBONATE HINGE KNUCKLE

OPTIONAL BACK PANEL  
 .100 [2.54] TH'K - ALUMINUM  
 .075 [1.91] TH'K - PAINTED STEEL  
 .188 [4.78] TH'K - PVC

(4X) EACH #10-32 BRASS INSERTS AND 316 STAINLESS STEEL FLANGE AND FEET SCREWS

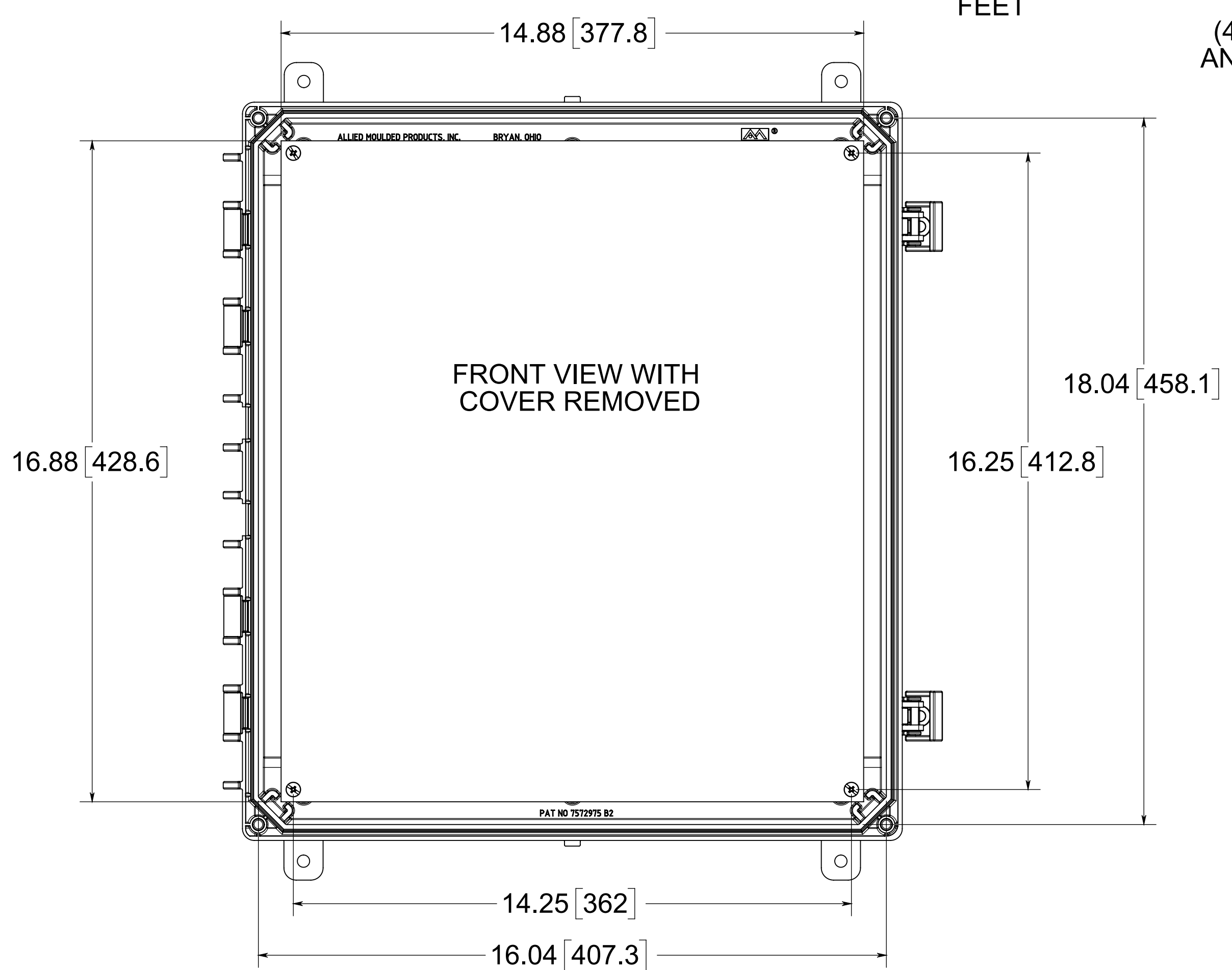
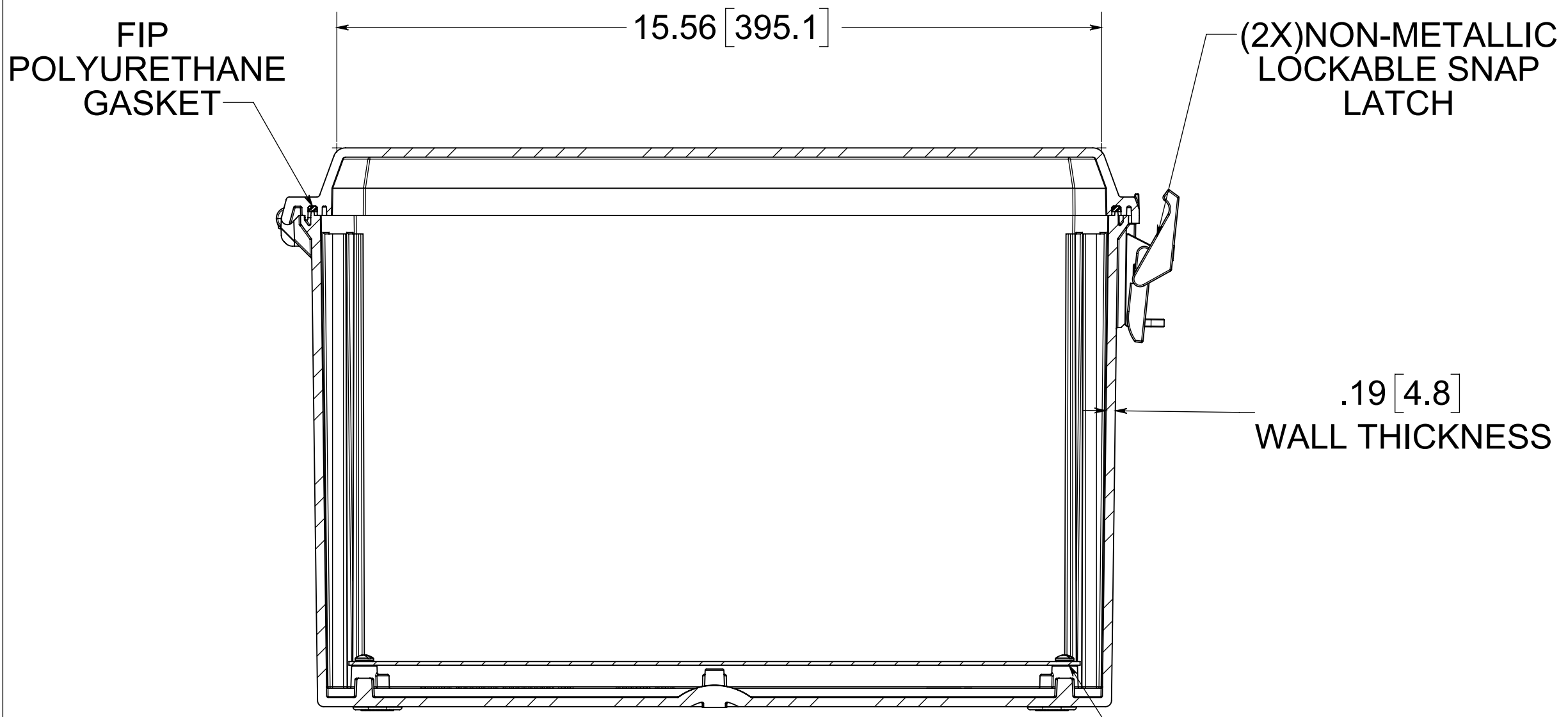

MATERIAL:  
 BOX: INJECTION POLYCARBONATE  
 STANDARD COVER: INJECTION POLYCARBONATE  
 CLEAR COVER: INJECTION POLYCARBONATE

NOTE: 1. DATA SUBJECT TO CHANGE

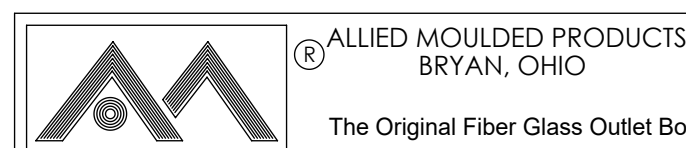

CONFIDENTIAL  
 THIS MATERIAL IS OWNED BY THE ALLIED MOULDED PRODUCTS COMPANY, IS DISCLOSED IN CONFIDENCE, AND IS NOT TO BE REPRODUCED OR DISTRIBUTED WITHOUT PRIOR WRITTEN PERMISSION FROM ALLIED MOULDED PRODUCTS.

Description  
**AMP Polyline**  
 Part No.  
**AMP1860NL.WEB**